

2

1

B

B

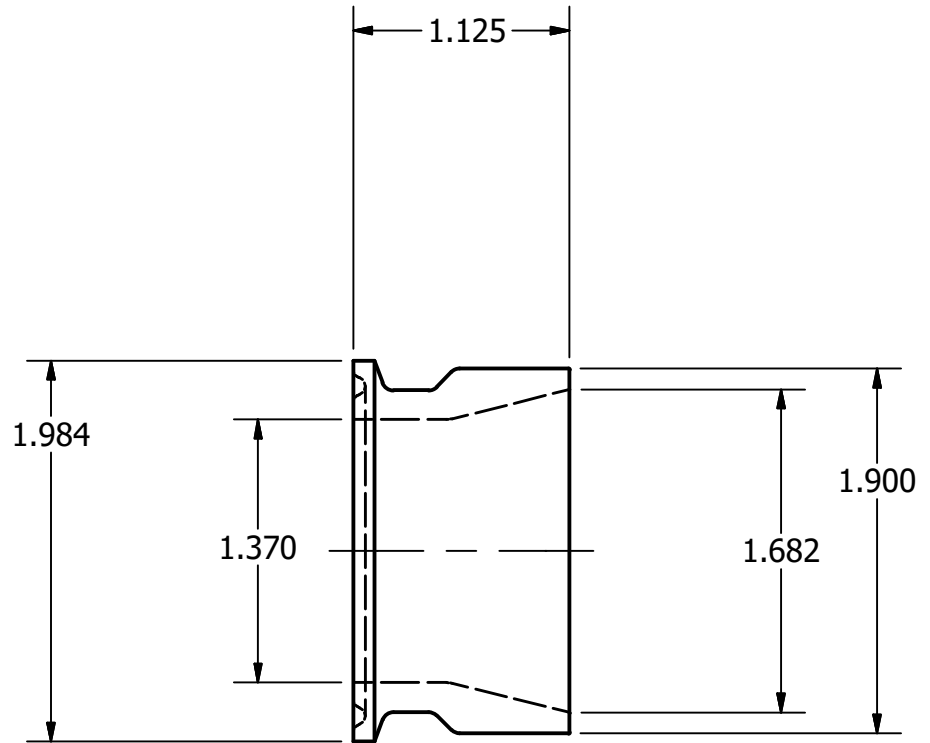

A

A

A

A

TOLERANCES	DRAWN M. Golabek 6/19/2006
DECIMALS: .XX ±.015 .XXX ±.005 .XXXX ±.0005 ANGLES: 1°	ALL EDGES AND FILLETS .015 R UNLESS OTHERWISE SPECIFIED

Steel & O'Brien Mfg. Inc.	
TITLE 1.500 TC X 1.500 SCH-10 REDUCER	
DWG NO: 19MPX-1.5	REV
SCALE: 1 : 1	SHEET 1 OF 1

2

1

