

ROW	# OF HOLES
1	8
2	8
3	8
4	8
5	8
6	8
7	8

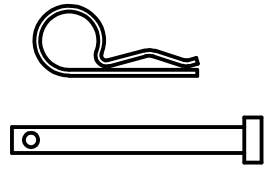

PIN/CLIP REQUIRED WITH EACH SPRAY BALL

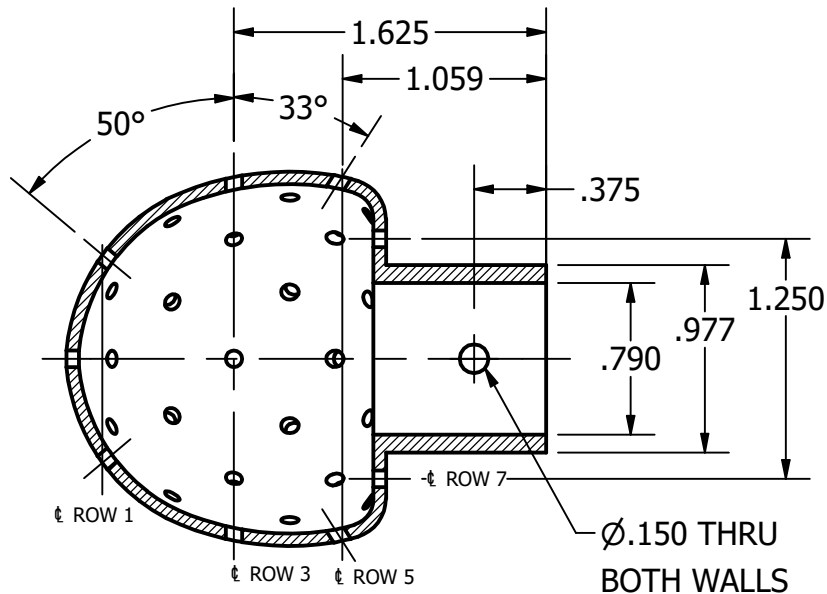

SECTION A-A

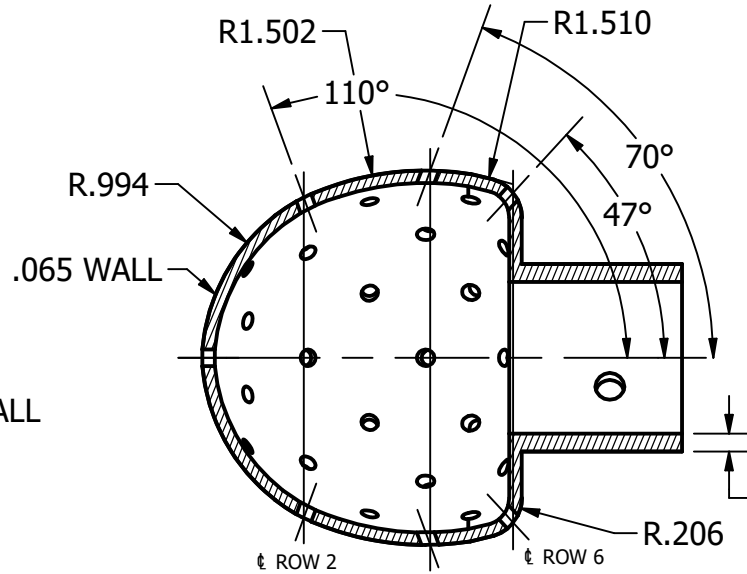

SECTION B-B

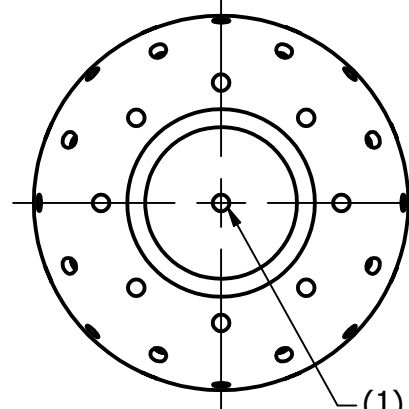

BOTTOM VIEW

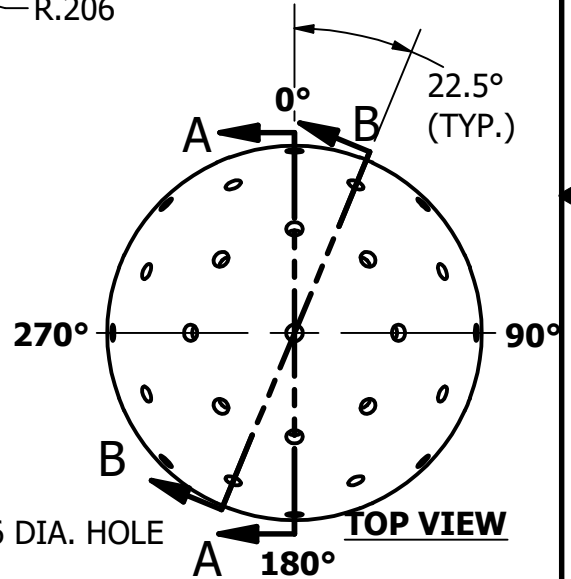
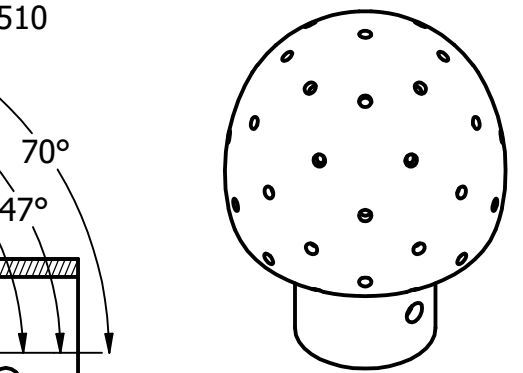

TOP VIEW

NOTES:

- (56) .086 DIA. HOLES TOTAL, HOLES IN EACH ROW ARE EQUALLY SPACED.
- REMOVE BURRS FROM I.D./O.D.
- MARKING TO BE ECHED, LEAVING A SMOOTH SURFACE.

TOLERANCES		DRAWN K. Lane 5/8/2018		Steel & O'Brien Mfg. Inc.	
DECIMALS: .XX ±.125 .XXX ±.050 ANGLES: 1°	UNLESS OTHERWISE NOTED:	>ALL WELDS ARE AUTOGENOUS BUTTWELD		TITLE	
		>WELDS POLISHED FLUSH		3/4" SLIP ON x 2" SPRAY BALL	
		>32Ra ID/OD		DWG NO: SBSA-.75X2	
		>REFER TO DOC# QS121 FOR GENERAL TOLERANCES		REV	
		SCALE: 1 : 1		SHEET 1 OF 1	