

Ø.750 THRU (4-TYP.)

Ø6.000

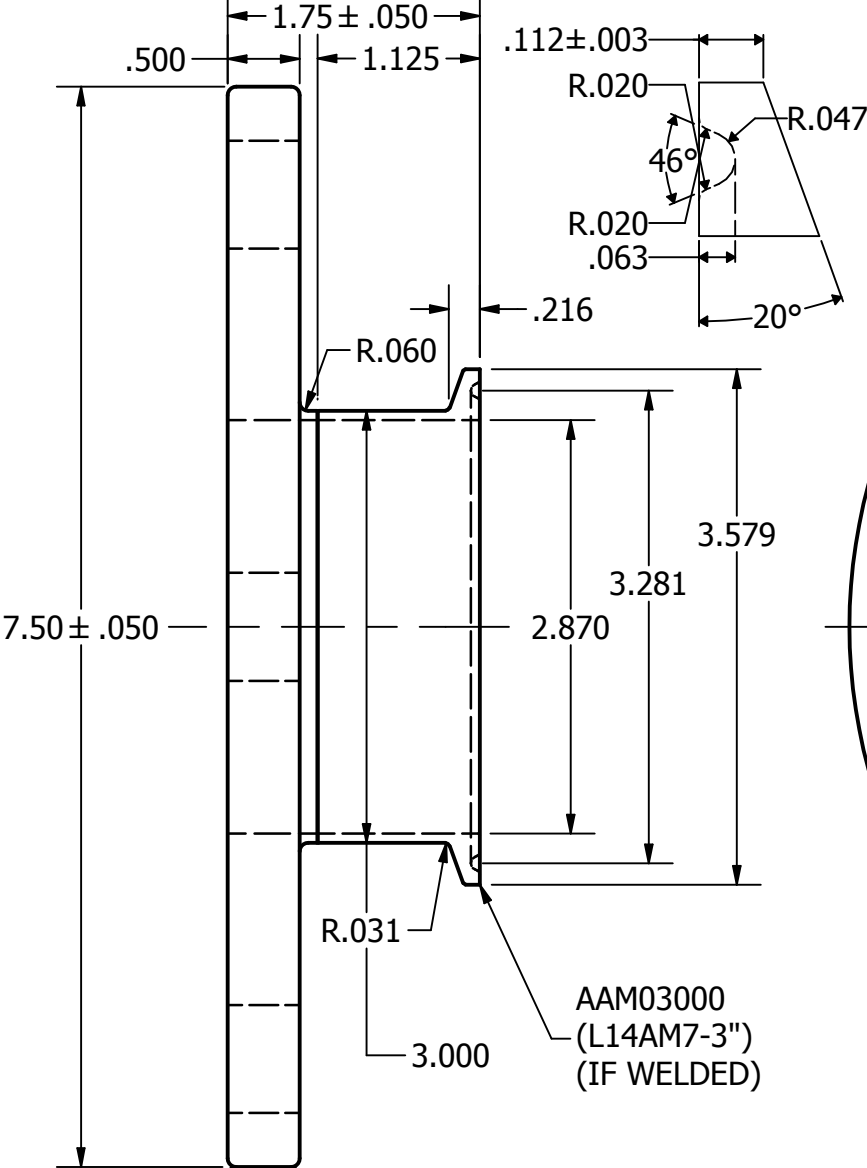

AAM03000  
(L14AM7-3")  
(IF WELDED)

DAS03000  
(38W-3)  
(IF WELDED)

TOLERANCES	DRAWN T. BAINBRIDGE 1/26/2016	Steel & O'Brien Mfg. Inc.	
	DECIMALS: .XX ±.015 .XXX ±.005 .XXXX ±.0005 ANGLES: 1°		
<ALL EDGES AND FILLETS .015 R UNLESS OTHERWISE SPECIFIED <REFER TO DOC# QS121 FOR GENERAL TOLERANCES		DWG NO: <b>DAJ03001</b>	REV
		SCALE: 3 : 4	SHEET 1 OF 1