

2

1



Size	"A"	"B"	"C"	"D"
1/2	2.750	.875	1.875	1.875
3/4	3.000	1.000	2.000	2.000
1	3.250	1.125	2.125	2.125
1 1/2	3.750	1.375	2.375	2.375
2	4.500	1.625	2.875	2.875
2 1/2	5.000	1.875	3.125	3.125
3	5.500	2.125	3.375	3.375
4	6.875	2.750	4.125	4.125
6	10.250	4.625	5.625	5.625

ALL DIMENSIONS ARE IN INCHES

B

B

A

A

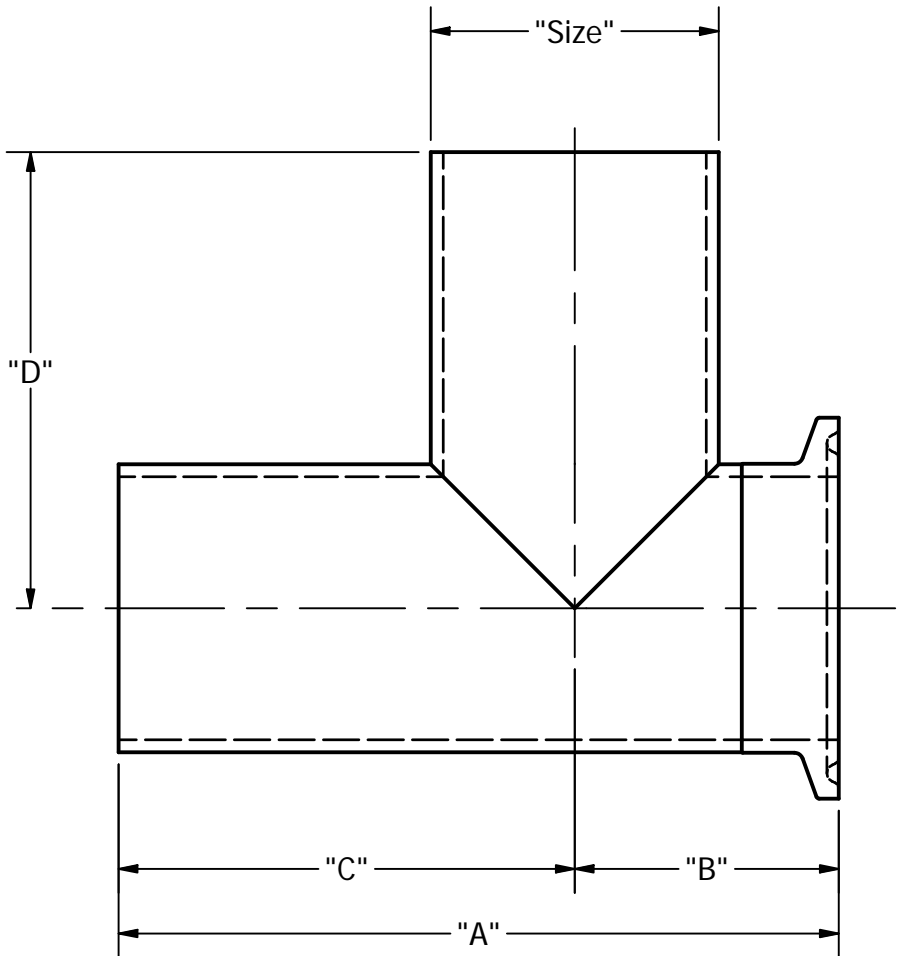

TOLERANCES & MATERIAL REFER TO LATEST ASME-BPE PUBLICATION	Steel & O'Brien Mfg. Inc.	
	TITLE EXTENDED TANGENT TEE W/ONE RUN SHORT S7WSKW	
	DWG NO: S7WSKW	REV
	SCALE: NTS	SHEET 1 OF 1

2

1