





















































---

# SUPERLOK Tube Fitting

- Double/Single Ferrule Compression Fittings
- Tubing Tools



## SUPERLOK Tube Fitting Index

UNION			TEE			O-RING SEAL		
	<b>SU</b> Union	9P		<b>SUT</b> Union Tee	33P		<b>SOSC</b> O-Seal Straight Thread Connector	51P
	<b>SRU</b> Reducing Union	10P		<b>SRUT</b> Reducing Union Tee	34P		<b>SOPC</b> O-Seal Pipe Thread Connector	51P
	<b>SBHRU</b> Bulkhead Reducing Union	11P		<b>SMBT</b> Male Branch Tee	35P		<b>SSMC</b> SAE/MS Male Connector	52P
	<b>SBHU</b> Bulkhead Union	12P		<b>SPMBT</b> Positionable Male Branch Tee	36P	<b>WELD END</b>		
<b>CONNECTOR</b>				<b>SMRT</b> Male Run Tee	37P		<b>SPWC</b> Male Pipe Weld Connector	56P
	<b>SMC</b> Male Connector	13P		<b>SPMRT</b> Positionable Male Run Tee	38P		<b>SMPWE</b> Male Pipe Weld Elbow	57P
	<b>SMC-GM</b> Male Connector for Metal Gasket Seal	17P		<b>SFBT</b> Female Branch Tee	39P		<b>SSWC</b> Tube Socket Weld Connector	57P
	<b>SGMC</b> Male Connector for Bonded Washer Seal	18P		<b>SFRT</b> Female Run Tee	40P		<b>SSWE</b> Tube Socket Weld Elbow	57P
	<b>SFC</b> Female Connector	19P		<b>SUC</b> Union Cross	41P	<b>PLUG &amp; CAP</b>		
	<b>SGC</b> Gauge Connector	21P	<b>STUB TUBE CONNECTOR</b>				<b>SP</b> Plug	58P
	<b>SMCB</b> Bulkhead Male Connector	22P		<b>SR</b> Reducer	42P		<b>SC</b> Cap	58P
	<b>SFCB</b> Bulkhead Female Connector	23P		<b>SRB</b> Bulkhead Reducer	44P	<b>SPARE PART</b>		
<b>ELBOWS</b>				<b>SMA</b> Male Adapter	45P		<b>SN</b> Nut	59P
	<b>SUE</b> Union Elbow	24P		<b>SFA</b> Female Adapter	46P		<b>SFF</b> Front Ferrule	59P
	<b>SHUE</b> 45° Union Elbow	25P		<b>SPC</b> Port Connector	47P		<b>SBF</b> Back Ferrule	60P
	<b>SME</b> Male Elbow	26P		<b>SRPC</b> Reducing Port Connector	48P		<b>SFS</b> Ferrule Set	60P
	<b>SHME</b> 45° Male Elbow	29P		<b>SFTC</b> Lap Joint Flange Tube Connector	49P	<b>AN TUBE</b>		
	<b>SPHME</b> 45° Positionable Male Elbow	30P		<b>SAF</b> An Flare	49P		<b>SI</b> Insert	60P
	<b>SPME</b> Positionable Male Elbow	31P		<b>SAU</b> An Union	50P		<b>SBHR</b> Bulkhead Retainer	61P
	<b>SFE</b> Female Elbow	32P		<b>SAA</b> An Adapter	50P		<b>SVP</b> Vent Protector	61P

## Ordering Information

**Example :**

$$\text{SMC} - \frac{\text{8}}{1} - \frac{\text{8N}}{2-1} - \frac{\text{B}}{2-2} - \frac{\text{3}}{3}$$

### 1. Type of Fitting

Please refer to SUPERLOK tube fitting index on page 2.

**Example :**

- SU** = Union       **SMC** = Male Connector       **SUE** = Union Elbow       **SUT** = Union Tee
- SWC** = Weld connector       **SR** = Reducer       **SAU** = An union       **SP** = Plug

### 2. Size of Fitting

#### 2-1. Tube O.D

Fractional Tube	OD (Inch)	1/16	1/8	3/16	1/4	5/16	3/8	1/2	5/8	3/4	7/8	1	1-1/4	1-1/2	2
	Designator	1	2	3	4	5	6	8	10	12	14	16	20	24	32
Metric Tube	OD (mm)	2	3	4	6	8	10	12	16	20	22	25	28	32	38
	Designator	2M	3M	4M	6M	8M	10M	12M	16M	20M	22M	25M	28M	32M	38M

#### 2-2. Pipe Thread Size or tube size

Size (inch)	1/8	1/4	3/8	1/2	3/4	1	Standards
ISO Tapered	2R	4R	6R	8R	12R	16R	JIS B0203(PT), DIN2999, BSPT
NPT	2N	4N	6N	8N	12N	16N	ANSI B1.20.1
ISO Parallel	2G	4G	6G	8G	12G	16G	JIS B0202(PF), ISO 228/1, BSPP
Unified Screw	2U	4U	6U	8U	12U	16U	AMERICAN STANDARD UNIFIED SCREW THREAD

### 3. Material

- (Blank)** = 316 Stainless Steel
- 36L** = 316L Stainless Steel
- B** = Brass
- AL** = Aluminum
- 15** = Carbon Steel A105
- S45C** = Carbon Steel S45C
- M40** = Monel Alloy 400
- 825** = Alloy 825
- 625** = Alloy 625
- 276** = Alloy C-276

### Ordering numbers for Tees and Crosses

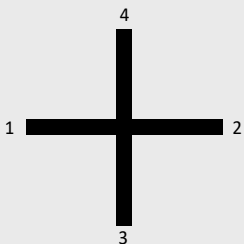

- TEE: First indicate the size of the run (1 to 2) and then the size of the branch (3).
- CROSS: First indicate the size of the run (1 to 2) and then the size of the branch (3 to 4).

**Ex. 1) SMBT - 6 - 6N**  
Male Branch Tee, 3/8" x 3/8" NPT, Stainless Steel 316

**Ex. 2) SUC - 8 - M40**  
Union Cross, 1/2"x1/2", Monel 400

※ For special sizes and configurations, please consult BMT (SUPERLOK) sales representative.

## Features of SUPERLOK Tube Fittings



### Structure of SUPERLOK

SUPERLOK Tube Fittings consist of four precision parts that are manufactured under the strictest of quality control. These four precision parts together make up the best Tube Fitting in the world. SUPERLOK Tube Fittings secure leak free connections providing customers with confidence and appreciation of overall reliability of the installed systems.



### SUPERLOK Installation Instruction

#### 1. Installation under 1 inch or 25MM

SUPERLOK Tube Fittings shall be delivered to the customer completely assembled and ready for installation.

Turning the nut to the finger tight position is the only requirement before starting the installation.

Fittings should not be disassembled before installation to maintain cleanliness and prevent unwanted foreign material from entering the system.

Care in the proper selection of tubing also contributes to a safe and reliable installation.

#### Step 1

Insert the tubing into the SUPERLOK Tube Fitting making sure the tubing is bottomed out and is in complete contact with the shoulder of the fitting. Also, the nut should be in the finger-tight position at this time.

#### Step 2

Before tightening, mark the SUPERLOK nut at the 6 o'clock position.

#### Step 3

Hold the fitting body safely with a back-up wrench and tighten the nut 1-1/4 turns until your mark reaches the 9 o'clock position.

Note: For 1/16", 1/8" and 3/16 inch; 2, 3 and 4 mm tube fittings, tighten the nut 3/4 of a turn to the 3 o'clock position.



Step1

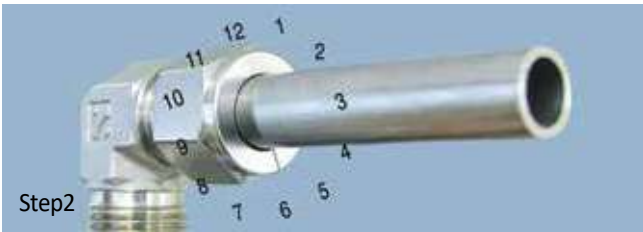

Step2

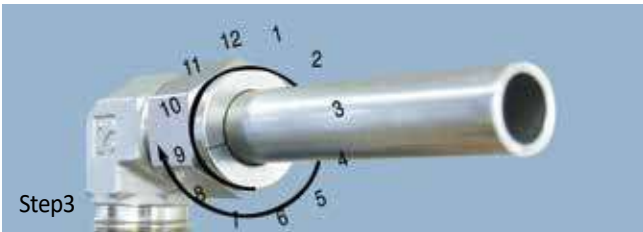

Step3

**Gaugeability**

On initial installation, the SUPERLOK Inspection Gauge assures the installer or inspector that a fitting has been sufficiently tightened.

Position the SUPERLOK Inspection Gauge next to the gap between the nut and the body.

- If the gauge will not enter the gap, the fitting is sufficiently tightened.
- If the gauge will enter the gap, additional tightening is required.



**2. Installation for high pressure or severe service systems**

Since tubing has different O.D. tolerances, it is important to have a common starting point to take out in dimensional variations. This is done by tightening the fitting slightly until the tubing can not freely rotate in the fitting as it can in the finger-tight position. At this point tighten the nut 1-1/4 turns.

**Safety Considerations on Installations for High Pressure Systems**

1. Make sure the proper tubing wall thickness is selected in accordance with pressure ratings (See Page 8). Tubing should have a hardness of HRB 80 or less.

2. Do not assemble or disassemble fittings when the system is pressurized.

**3. Re-tightening Instructions**

**Step 1**

Pic. 1 shows the fitting in the disconnected position. Insert the tubing with the pre-swaged ferrules into the fitting body making sure the front ferrule is firmly seated as shown in Pic. 2

**Step 2**

Finger-tighten the nut and then with a wrench turn the nut to the original 9 o'clock position. At this point a slight change of resistance will be felt. Tighten the nut slightly more as the change in resistance is felt and the installation is complete as shown in Pic. 3 by tightening slightly more.



Pic.1



Pic.2

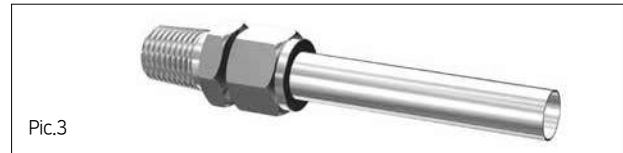

Pic.3

**Technical Information**

**Hardness Limitation**

High quality stainless steel tubing that is fully annealed; Seamless or Welded per ASTM A269, A213 or equivalent should be used with SUPERLOK Tube fittings. The tubing must be a maximum hardness of HRB 90 or less on the Rockwell Scale, however HRB 80 is more suitable for bending and offers a greater difference in hardness to the ferrules. This difference in hardness offers more ease in assembly and better interaction between the ferrules and the tubing.

**Compatibility**

SUPERLOK Tube fittings are designed and manufactured to be interchangeable with other Tube Fittings manufactured by other industry leading manufacturers. When required compatibility testing can be performed by an independent third party and the reports can be provided. Please consult BMT(SUPERLOK) sales representative for compatibility



### Gas System Application

SUPERLOK Tube Fittings are appropriate for Gas Systems, but the implementation of certain standards mentioned below should be adhered to just as in other systems.

1. Tubing hardness must be less than that of the ferrules.
2. Tubing should be free of surface imperfections, defects and round in shape.
3. Refer to Table 2 on page 8 for selection of the appropriate wall thickness. (Only shaded areas should be selected for Gas Systems)
4. Tubing ends must be cut squarely and perpendicular to the center-line of the tubing. After the tubing is cut it must be deburred on both the inside and outside with a High quality fully sharpened deburring tool.
5. Follow the SUPERLOK Installation Instructions from pages 4 to 5 in the catalog.
6. Do not attempt to bend the tubing after a fitting has been Installed in a fixed position.
7. Tubing Systems should be installed to allow for adequate expansion and contraction as well as ease of maintenance.

### Material

Material	Bar Stock	Forging
316 SS	ASTM A479 ASTM A276	ASTM A182
Monel, Alloy 400	ASTM B164	ASTM B564
Inconel, Alloy 600	ASTM B166	ASTM B564
Hastelloy, Alloy C-276	ASTM B574	ASTM B564
Brass	ASTM B16 ASTM B453	ASTM B283

SUPERLOK tube fitting are available as standard in stainless steel, brass, and alloy material. Straight fittings are machined from cold finished bar stock and shaped bodies are from forgings Specifications for fitting materials are listed above. For special applications, contact your local distributors.

### Maximum Temperature by Materials

Aluminum	400 °F	204 °C
Copper	400 °F	204 °C
Steel	375 °F	191 °C
SUS304	1000 °F	538 °C
SUS316	1200 °F	649 °C
MONEL	800 °F	427 °C

Please refer to ASME B31.3 concerning the detailed information about the maximum & minimum temperature of various materials.

### Vacuum, Cryogenic and High Temperature Applications

SUPERLOK Tube Fittings have been tested in vacuum, Cryogenic and High Temperatures insuring repeatable and reliable performance in the severest of applications.

### Threads

#### 1. NPT (National Pipe Thread)

- Thread angle 60°
- Tapered angle 1° 47'
- Manufactured by the standard of ASME B 1.20.1

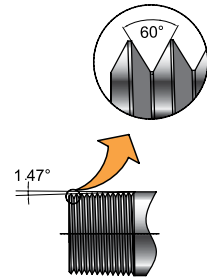

#### 2. ISO 7/1 Taperad Thread

- Thread angle 55°
- Tapered angle 1° 47'
- Equivalent to the standard of DIN2999, BS21(BSPT) and JIS B0203(PT).

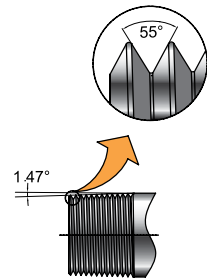

#### 3. ISO 228/1 Parallel Thread

- Thread angle 55°
- Equivalent to the standard of BS 2779 (BSPP), JIS B0202 (PF).
- As the thread in accordance with ISO 228/1 cannot be sealed perfectly, the sealing shall be done by the following method.
- Use a gasket or O-Ring to seal.

#### ① Bonded Washer Seal

Be sealed by contacting the inclined surface of the hex body of male thread to the surface of the female thread. In case of sealing, a washer which composed of metal and elastic material is located at the center of tapered surface.

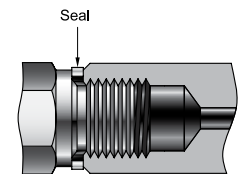

#### ② Metal Gasket Seal

A Metal gasket(generally copper) is sealed between the body of male thread and the surface of female thread.

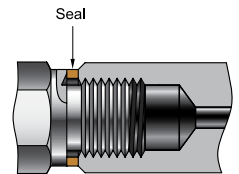

#### ③ Metal Gasket Seal

This is a method to insert a gasket into the flat surface of thread's inside. The sealing shall be completed with pushing the gasket by male thread surface.

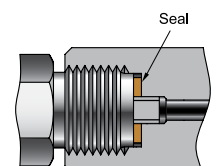

**4. UNF Thread**

- Thread angle 60°
- This is classified into UN, UNC and UNF. The standard is classified by the diameter of thread and the number of threads per inch.
- ASME B 1.1

**Tube Standard Information**

**Tube Selection**

Suitable tubing selection is essential in performance of tubing system. When selecting tubing material, size and wall thickness, customer must consider pressure, flux (flow), temperature, environment and compatibility of system.

**Consideration facts at the selection of tube**

1. Quality of the tube materials & manufacturing method.
2. Thickness and outer diameter of tube.
3. Surface treatment of tube.
4. Hardness of tube.
5. Concentricity of tube.

**Tube Bending**

Tubing must have a minimum straight length before the start of any bend when inserting the tube into a SUPERLOK Tube Fitting. Tubing where the minimum straight length is not adhered can result in leakage and jeopardize the integrity of the system.

See the chart below for minimum straight lengths.

**The recommended straight line length of tube in Tube bending**

Tube OD (inch)	1/8	3/16	1/4	5/16	3/8	1/2	5/8	3/4	7/8	1
*L(mm)	12.70	18.25	19.05	20.63	22.20	23.81	30.16	31.75	33.30	38.10

\*L: The straight line length of tubing from the ending part of tubing to the beginning part of bending

**Quality of Tubing Material**

Tubing must be free of surface imperfections and suitable for Bending.

**Carbon steel tubing**

- ASTM A179 or equivalent.
- Carbon steel tubing for an oil pressure usage of high quality, annealed and seamless.
- Maximum hardness : HRB72.

- Tubing must be free from scars and shall be suitable for bending and expansion works.

**Copper tubing**

- ASTM B68, B75 or equivalent.
- Copper tubing of high quality, annealed and seamless.

**Stainless steel tubing**

- ASTM A213, A269 or equivalent.
- Stainless steel tubing of high quality, annealed and seamless. (316, 304, 321, etc.)
- Hardness : below HRB 80.
- Tubing must be free from scars and shall be suitable for bending and expansion works.

**Monel tubing**

- ASTM B165 or equivalent.
- 400 alloy tubing of high quality, annealed and seamless
- Hardness : below HRB 75.
- Tubing must be free from scars and shall be suitable for bending and expansion works.

**A pressure Grade Coefficient of Tubing owing to Temperature Change.**

**Table 1**

° F	° C	Copper	304SS	316SS	Monel
200	93	0.80	1.00	1.00	0.88
400	204	0.50	0.93	0.96	0.79
600	316	---	0.82	0.85	0.79
800	427	---	0.76	0.79	0.76
1000	538	---	0.69	0.76	---
1200	649	---	0.30	0.37	---

Multiply the allowable working pressure in Table 2 by the coefficient in Table1 in order to decide allowable pressure at high temperature. (See page 7, 8)

**Example**

SS316  
 (3/8" O.D of tube) X (0.049" wall thickness)  
 1200°F : 4800 psi X 0.37 = 1776 psi

The applicable operation pressure of SS 316 tubing for wall thickness 3/8" O.D x 0.049" is 1776 psi at 1200°F.

**Table 2 Stainless Steel Tubing**

Stainless Steel tubing which is high quality (such as 304, 316, 316L and so on), fully annealed and seamless ASTM A269, A213 or equivalent.

**STAINLESS STEEL FRACTIONAL TUBE**

Tube OD (inch)	TUBE WALL THICKNESS (inch)												
	0.010	0.012	0.014	0.016	0.020	0.028	0.035	0.049	0.065	0.083	0.095	0.109	0.120
1/16	5600	6800	8100	9400	12000								
1/8						8500	10900						
3/16						5400	7000	10200					
1/4						4000	5100	7500	10200				
5/16							4000	5800	8000				
3/8							3300	4800	6500				
1/2							2600	3700	5100	6700			
5/8								2900	4000	5200	6000		
3/4								2400	3300	4200	4900	5800	
7/8								2000	2800	3600	4200	4800	
1									2400	3100	3600	4200	4700

\* 가스용 Tubing working pressure(psi) / 허용상용압력(psi)

**STAINLESS STEEL METRIC TUBE**

Tube OD (mm)	TUBE WALL THICKNESS (mm)												
	0.71	0.89	1.00	1.25	1.50	1.65	2.00	2.11	2.41	2.50	2.77	3.00	3.05
3	10800	13800	15300										
4	7900	10100	11500	14400									
6	5000	6500	7400	9400	11500	12700							
8		4700	5800	6800	8400	9300							
10		3700	4200	5300	6500	7300							
12		3000	3400	4400	5300	5900	6800	7200					
16			2500	3200	3900	4300	5300	5700	6600	6800			
18				2800	3400	3800	4700	5000	5800	6000	6700		
20				2500	3000	3400	4200	4400	5100	5300	6000		
22				2300	2800	3000	3800	4000	4600	4800	5400		
25				2000	2400	2700	3300	3500	4000	4200	4700	5100	5200

\* 가스용 Tubing working pressure(psi) / 허용상용압력(psi)

Allowable stress value between -20°F and 100°F (-28.9°C ~ 37.8°C) is 19,500 psi

Safety factor is 4 (Ultimate tensile strength is 75,000 psi)

- The above data are based on the minimum wall thickness and the maximum O. D. allowed by and under the standard of ASTM A269.
- The dimensions are not considered to erosion or corrosion.



# SU

## Union

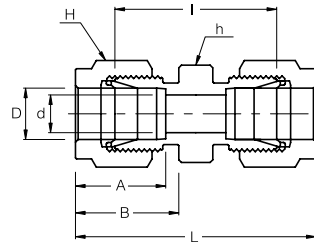

### Connects Fractional Tubes

Part No.	Tube OD D (inch)	d Min	Width Across Flat		A	B	I	L
			h (inch)	H (inch)				
SU - 1	1/16	1.27	5/16	5/16	8.63	10.92	17.52	25.15
SU - 2	1/8	2.28	7/16	7/16	12.70	15.24	22.35	35.56
SU - 3	3/16	3.04	7/16	1/2	13.71	16.00	24.13	37.33
SU - 4	1/4	4.82	1/2	9/16	15.24	17.78	26.16	40.89
SU - 5	5/16	6.35	9/16	5/8	16.25	18.54	28.19	42.92
SU - 6	3/8	7.11	5/8	11/16	16.76	19.30	30.22	44.95
SU - 8	1/2	10.41	13/16	7/8	22.86	21.84	30.98	51.30
SU - 10	5/8	12.70	15/16	1	24.38	21.84	31.75	52.07
SU - 12	3/4	15.74	1-1/16	1-1/8	24.38	21.84	33.27	53.59
SU - 14	7/8	18.28	1-3/16	1-1/4	25.90	21.84	34.79	55.11
SU - 16	1	22.35	1-3/8	1-1/2	31.24	26.41	40.38	64.77
SU - 20	1-1/4	27.69	1-3/4	1-7/8	41.15	38.86	48.00	92.20
SU - 24	1-1/2	34.04	2-1/8	2-1/4	50.04	45.21	53.59	107.95
SU - 32	2	45.97	2-3/4	3	67.56	62.74	74.68	149.35

### Connects Metric Tubes

Part No.	Tube OD D	d Min	Width Across Flat		A	B	I	L
			h	H				
SU - 2M	2	1.7	12	12	12.9	15.3	22.4	35.6
SU - 3M	3	2.4	12	12	12.9	15.3	22.1	35.3
SU - 4M	4	2.4	12	12	13.7	16.1	24.1	37.3
SU - 6M	6	4.8	14	14	15.3	17.7	26.2	41.0
SU - 8M	8	6.4	15	16	16.2	18.6	28.2	43.2
SU - 10M	10	7.9	18	19	17.2	19.5	31.0	46.2
SU - 12M	12	9.5	22	22	22.8	22.0	31.0	51.2
SU - 15M	15	11.9	24	25	24.4	22.0	31.8	52.0
SU - 16M	16	12.7	24	25	24.4	22.0	31.8	52.0
SU - 18M	18	15.1	27	30	24.4	22.0	33.3	53.5
SU - 20M	20	15.9	30	32	26.0	22.0	34.8	55.0
SU - 22M	22	18.3	30	32	26.0	22.0	34.8	55.0
SU - 25M	25	21.8	35	38	31.3	26.5	40.4	65.0

- Dimensions and Drawings are for reference only and are subject to change without prior notice.
- Unless otherwise specified, all dimensions are in millimeters.
- Sizes, pressure classes, and end connections not listed are available upon request.
- Dimensions shown with SUPERLOK nuts finger-tight, where applicable.

# SRU

## Reducing Union

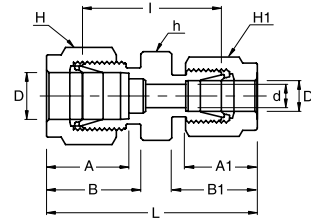

### Connects Fractional Tubes

Part No.	Tube OD		d Min	Width Across Flat			A	A1	B	B1	I	L
	D (inch)	D1 (inch)		h (inch)	H (inch)	H1 (inch)						
SRU - 2 - 1	1/8	1/16	1.27	7/16	7/16	5/16	12.7	8.63	15.24	10.92	20.60	31.00
SRU - 3 - 2	3/16	1/8	2.28	7/16	1/2	7/16	13.71	12.70	16.00	15.24	23.36	36.57
SRU - 4 - 2	1/4	1/8	2.28	1/2	9/16	7/16	15.24	12.70	17.78	15.24	24.63	38.60
SRU - 4 - 3	1/4	3/16	3.04	1/2	9/16	1/2	15.24	13.71	17.78	16.00	25.40	39.37
SRU - 5 - 2	5/16	1/8	2.28	9/16	5/8	7/16	16.25	12.70	18.54	15.24	25.90	39.87
SRU - 5 - 4	5/16	1/4	4.82	9/16	5/8	9/16	16.25	15.24	18.54	17.78	27.43	42.16
SRU - 6 - 2	3/8	1/8	2.28	5/8	11/16	7/16	16.76	12.70	19.30	15.24	26.92	40.89
SRU - 6 - 4	3/8	1/4	4.82	5/8	11/16	9/16	16.76	15.24	19.30	17.78	28.44	43.18
SRU - 6 - 5	3/8	5/16	6.35	5/8	11/16	5/8	16.76	16.25	19.30	18.54	29.46	44.19
SRU - 8 - 2	1/2	1/8	2.28	13/16	7/8	7/16	22.86	12.70	21.84	15.24	28.44	45.21
SRU - 8 - 4	1/2	1/4	4.82	13/16	7/8	9/16	22.86	15.24	21.84	17.78	29.46	46.99
SRU - 8 - 6	1/2	3/8	7.11	13/16	7/8	11/16	22.86	16.76	21.84	19.30	30.98	48.51
SRU -10 - 6	5/8	3/8	7.11	15/16	1	11/16	24.38	16.76	21.84	19.30	31.75	49.27
SRU -10 - 8	5/8	1/2	10.41	15/16	1	7/8	24.38	22.86	21.84	21.84	31.75	52.07
SRU -12 - 4	3/4	1/4	4.82	1-1/16	1-1/8	9/16	24.38	15.24	21.84	17.78	31.75	49.27
SRU -12 - 6	3/4	3/8	7.11	1-1/16	1-1/8	11/16	24.38	16.76	21.84	19.30	33.27	50.80
SRU -12 - 8	3/4	1/2	10.41	1-1/16	1-1/8	7/8	24.38	22.86	21.84	21.84	33.27	53.59
SRU -12 - 10	3/4	5/8	12.70	1-1/16	1-1/8	1	24.38	24.38	21.84	21.84	33.27	53.59
SRU -16 - 8	1	1/2	10.41	1-3/8	1-1/2	7/8	31.24	22.86	26.41	21.84	39.50	63.24
SRU -16 - 12	1	3/4	15.74	1-3/8	1-1/2	1-1/8	31.24	24.38	26.41	21.84	39.00	62.73

### Connects Metric Tubes

Part No.	Tube OD		d Min	Width Across Flat			A	A1	B	B1	I	L
	D	D1		h	H	H1						
SRU - 6M - 3M	6	3	2.4	14	14	12	15.3	12.9	17.7	15.3	24.6	38.6
SRU - 6M - 4M	6	4	2.4	14	14	12	15.3	13.7	17.7	16.1	25.4	39.4
SRU - 8M - 6M	8	6	4.8	15	16	14	16.2	15.3	18.6	17.7	27.4	42.3
SRU - 10M - 6M	10	6	4.8	18	19	14	17.2	15.3	19.5	17.7	29.5	44.5
SRU - 10M - 8M	10	8	6.4	18	19	16	17.2	16.2	19.5	18.6	30.0	45.1
SRU - 12M - 6M	12	6	4.8	22	22	14	22.8	15.3	22.0	17.7	29.5	47.0
SRU - 12M - 8M	12	8	6.4	22	22	16	22.8	16.2	22.0	18.6	30.2	47.8
SRU - 12M - 10M	12	10	7.9	22	22	19	22.8	17.2	22.0	19.5	31.0	48.7
SRU - 16M - 12M	16	12	9.5	24	25	22	24.4	22.8	22.0	22.0	31.8	52.0
SRU - 25M - 18M	25	18	15.1	35	38	30	31.3	24.4	26.5	22.0	38.6	61.0
SRU - 25M - 20M	25	20	15.9	35	38	32	31.3	26.0	26.5	22.0	39.9	62.3

- Dimensions and Drawings are for reference only and are subject to change without prior notice.
- Unless otherwise specified, all dimensions are in millimeters.
- Sizes, pressure classes, and end connections not listed are available upon request.
- Dimensions shown with SUPERLOK nuts finger-tight, where applicable.

# SRU

## Reducing Union

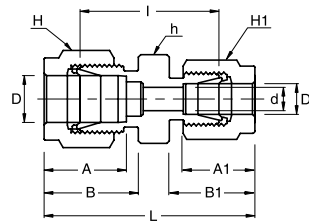

### Connects Fractional Tubes To Metric Tubes

Part No.	Tube OD		d Min	Width Across Flat			A	A1	B	B1	I	L
	D1 (inch)	D		h	H	H						
SRU - 2 - 3M	1/8	3	2.4	12	12	11.1	12.9	12.8	15.3	15.2	22.1	35.2
SRU - 2 - 4M	1/8	4	2.4	12	12	11.1	13.7	12.8	16.1	15.2	23.4	36.5
SRU - 4 - 4M	1/4	4	2.4	14	12	14.3	13.7	15.3	16.1	17.7	25.4	39.4
SRU - 2 - 6M	1/8	6	2.4	14	14	11.1	15.3	12.8	17.7	15.2	24.6	38.5
SRU - 4 - 6M	1/4	6	4.8	14	14	14.3	15.3	15.3	17.7	17.7	26.2	41.0
SRU - 5 - 6M	5/16	6	4.8	14	14	15.9	15.3	16.2	17.7	18.6	27.4	42.3
SRU - 4 - 8M	1/4	8	4.8	15	16	14.3	16.2	15.3	18.6	17.7	27.4	42.3
SRU - 2 - 10M	1/8	10	2.4	18	19	11.1	17.2	12.8	19.5	15.2	27.7	41.8
SRU - 4 - 10M	1/4	10	4.8	18	19	14.3	17.2	15.3	19.5	17.7	29.5	44.5
SRU - 5 - 10M	5/16	10	6.4	18	19	15.9	17.2	16.2	19.5	18.6	30.0	45.1
SRU - 6 - 10M	3/8	10	7.1	18	19	17.5	17.2	16.9	19.5	19.2	31.0	45.9
SRU - 5 - 12M	5/16	12	6.4	22	22	15.9	22.8	16.2	22.0	18.6	30.2	47.8
SRU - 6 - 12M	3/8	12	7.1	22	22	17.5	22.8	16.9	22.0	19.2	31.0	48.4
SRU - 8 - 12M	1/2	12	9.5	22	22	22.2	22.8	22.8	22.0	22.0	31.0	51.2
SRU - 8 - 15M	1/2	15	10.3	24	25	22.2	24.4	22.8	22.0	22.0	31.8	52.0
SRU - 10 - 16M	5/8	16	12.7	24	25	25.4	24.4	24.4	22.0	22.0	31.8	52.0
SRU - 12 - 18M	3/4	18	15.1	27	30	28.6	24.4	24.4	22.0	22.0	33.3	53.5
SRU - 12 - 20M	3/4	20	15.9	30	32	28.6	26.0	24.4	22.0	22.0	34.8	54.9
SRU - 16 - 20M	1	20	15.9	35	32	38.1	26.0	31.2	22.0	26.4	40.4	62.8
SRU - 16 - 25M	1	25	21.8	35	38	38.1	31.3	31.3	26.5	26.5	40.4	65.0

# SBHRU

## Bulkhead Reducing Union

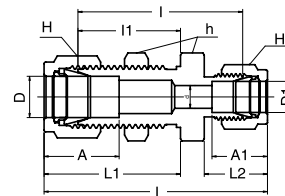

### Connects Fractional Tubes

Part No.	Tube OD		d Min	Width Across Flat			A	A1	I	I1	L	L1	L2	Panel Hole Drill Size	Panel Max. Thickness
	D (inch)	D1 (inch)		h (inch)	H (inch)	H1 (inch)									
SBHRU - 4 - 2	1/4	1/8	2.28	5/8	9/16	7/16	15.24	12.70	41.14	26.16	55.11	33.52	15.24	11.50	10.16
SBHRU - 6 - 4	3/8	1/4	4.82	3/4	11/16	9/16	16.76	15.24	45.97	29.46	60.70	36.57	17.78	14.68	11.17
SBHRU - 8 - 4	1/2	1/4	4.82	15/16	7/8	9/16	22.86	15.24	49.27	31.75	66.80	41.91	17.78	19.44	12.70

- Dimensions and Drawings are for reference only and are subject to change without prior notice.
- Unless otherwise specified, all dimensions are in millimeters.
- Sizes, pressure classes, and end connections not listed are available upon request.
- Dimensions shown with SUPERLOK nuts finger-tight, where applicable.

# SBHU

## Bulkhead Union

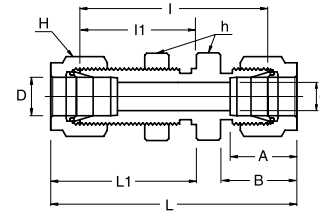

### Connects Fractional Tubes

Part No.	Tube O.D. D (inch)	d Min	Width Across Flat		A	B	I	I1	L	L1	Panel Hole Drill Size	Panel Max. Thickness
			h (inch)	H (inch)								
SBHU - 1	1/16	1.27	5/16	5/16	8.63	10.92	23.87	13.46	31.50	17.27	5.16	3.05
SBHU - 2	1/8	2.28	1/2	7/16	12.70	15.24	38.10	24.63	51.30	31.24	8.33	12.70
SBHU - 3	3/16	3.04	9/16	1/2	13.71	16.00	40.38	25.40	53.59	32.00	9.92	12.70
SBHU - 4	1/4	4.82	5/8	9/16	15.24	17.78	42.92	26.16	57.65	33.52	11.50	10.16
SBHU - 5	5/16	6.35	11/16	5/8	16.25	18.54	45.97	28.44	60.70	35.81	13.09	11.17
SBHU - 6	3/8	7.11	3/4	11/16	16.76	19.30	47.49	29.46	62.23	36.83	14.68	11.17
SBHU - 8	1/2	10.41	15/16	7/8	22.86	21.84	50.80	31.75	71.12	41.91	19.44	12.70
SBHU - 10	5/8	12.70	1-1/16	1	24.38	21.84	52.32	32.51	72.64	42.67	22.62	12.70
SBHU - 12	3/4	15.74	1-3/16	1-1/8	24.38	21.84	58.67	37.33	78.99	47.49	25.79	16.76
SBHU - 14	7/8	18.28	1-3/8	1-1/4	25.90	21.84	64.26	42.92	84.58	53.08	28.97	19.05
SBHU - 16	1	22.35	1-5/8	1-1/2	31.24	26.41	71.37	45.21	95.75	57.40	33.73	19.05

### Connects Metric Tubes

Part No.	Tube O.D. D	d Min	Width Across Flat			A	B	I	I1	L	L1	Panel Hole Drill Size	Panel Max. Thickness
			h	h1*	H								
SBHU - 3M	3	2.4	14	12.7	12	12.9	15.3	38.1	24.6	51.3	31.2	8.3	12.7
SBHU - 4M	4	2.4	14	14.3	12	13.7	16.1	40.4	25.4	53.6	32.0	9.9	12.7
SBHU - 6M	6	4.8	16	15.9	14	15.3	17.7	42.9	26.2	57.7	33.6	11.5	10.2
SBHU - 8M	8	6.4	18	17.5	16	16.2	18.6	46.0	28.6	61.0	36.1	13.1	11.2
SBHU - 10M	10	7.9	22	22.0	19	17.2	19.5	48.5	29.4	63.7	37.0	16.2	11.2
SBHU - 12M	12	9.5	24	23.8	22	22.8	22.0	50.8	31.8	71.0	41.9	19.5	12.7
SBHU - 15M	15	11.9	27	27.0	25	24.4	22.0	52.3	32.5	72.5	42.6	22.8	12.7
SBHU - 16M	16	12.7	27	27.0	25	24.4	22.0	52.3	32.5	72.5	42.6	22.8	12.7
SBHU - 18M	18	15.1	30	30.0	30	24.4	22.0	58.7	37.3	78.9	47.4	26.0	16.8
SBHU - 20M	20	15.9	35	35.0	32	26.0	22.0	64.3	42.9	84.5	53.0	29.0	17.0
SBHU - 22M	22	18.3	35	35.0	32	26.0	22.0	64.3	42.9	84.5	53.0	29.0	19.1
SBHU - 25M	25	21.8	41.3	41.3	38	31.3	26.5	71.4	45.2	95.9	57.5	33.7	19.1

h1\* : Metric Tubes Bulkhead Hexagon application only

- Dimensions and Drawings are for reference only and are subject to change without prior notice.
- Unless otherwise specified, all dimensions are in millimeters.
- Sizes, pressure classes, and end connections not listed are available upon request.
- Dimensions shown with SUPERLOK nuts finger-tight, where applicable.

# SMC

## Male Connector

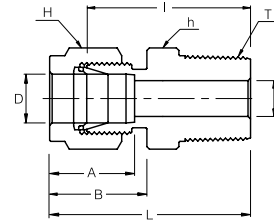

### Connects Fractional Tubes To Female NPT Thread

Part No.	Tube OD D (inch)	T (NPT)	d Min	Width Across Flat		A	B	I	L
				h (inch)	H (inch)				
SMC - 1 - 1N	1/16	1/16	1.27	5/16	5/16	8.63	10.92	20.00	23.83
SMC - 1 - 2N	1/16	1/8	1.27	7/16	7/16	8.63	10.92	22.35	26.23
SMC - 2 - 2N	1/8	1/8	2.28	7/16	7/16	12.70	15.24	23.87	30.48
SMC - 2 - 4N	1/8	1/4	2.28	9/16	7/16	12.70	15.24	28.95	35.56
SMC - 2 - 6N	1/8	3/8	2.28	11/16	7/16	12.70	15.24	29.21	35.81
SMC - 2 - 8N	1/8	1/2	2.28	7/8	7/16	12.70	15.24	35.56	42.16
SMC - 3 - 2N	3/16	1/8	3.04	7/16	1/2	13.71	16.00	24.63	31.24
SMC - 3 - 4N	3/16	1/4	3.04	9/16	1/2	13.71	16.00	29.71	36.32
SMC - 4 - 2N	1/4	1/8	4.82	1/2	9/16	15.24	17.78	25.40	32.76
SMC - 4 - 4N	1/4	1/4	4.82	9/16	9/16	15.24	17.78	30.48	37.84
SMC - 4 - 6N	1/4	3/8	4.82	11/16	9/16	15.24	17.78	30.98	38.35
SMC - 4 - 8N	1/4	1/2	4.82	7/8	9/16	15.24	17.78	37.33	44.70
SMC - 4 - 12N	1/4	3/4	4.82	1-1/16	9/16	15.24	17.78	38.86	46.22
SMC - 5 - 2N	5/16	1/8	4.82	9/16	5/8	16.25	18.54	26.67	34.03
SMC - 5 - 4N	5/16	1/4	6.35	9/16	5/8	16.25	18.54	31.24	38.60
SMC - 5 - 6N	5/16	3/8	6.35	11/16	5/8	16.25	18.54	31.75	39.11
SMC - 6 - 2N	3/8	1/8	4.82	5/8	11/16	16.76	19.30	27.94	35.30
SMC - 6 - 4N	3/8	1/4	7.11	5/8	11/16	16.76	19.30	32.51	39.87
SMC - 6 - 6N	3/8	3/8	7.11	11/16	11/16	16.76	19.30	32.51	39.87
SMC - 6 - 8N	3/8	1/2	7.11	7/8	11/16	16.76	19.30	38.86	46.22
SMC - 6 - 12N	3/8	3/4	7.11	1-1/16	11/16	16.76	19.30	40.38	47.75
SMC - 8 - 2N	1/2	1/8	4.82	13/16	7/8	22.86	21.84	28.70	38.86
SMC - 8 - 4N	1/2	1/4	7.11	13/16	7/8	22.86	21.84	33.27	43.43
SMC - 8 - 6N	1/2	3/8	9.65	13/16	7/8	22.86	21.84	33.27	43.43
SMC - 8 - 8N	1/2	1/2	10.41	7/8	7/8	22.86	21.84	38.86	49.02
SMC - 8 - 12N	1/2	3/4	10.41	1-1/16	7/8	22.86	21.84	40.38	50.54
SMC - 8 - 16N	1/2	1	10.41	1-3/8	7/8	22.86	21.84	46.99	57.15
SMC - 10 - 6N	5/8	3/8	9.65	15/16	1	24.38	21.84	34.03	44.19
SMC - 10 - 8N	5/8	1/2	11.93	15/16	1	24.38	21.84	38.86	49.02
SMC - 10 - 12N	5/8	3/4	12.70	1-1/16	1	24.38	21.84	40.38	50.54
SMC - 12 - 8N	3/4	1/2	11.93	1-1/16	1-1/8	24.38	21.84	40.38	50.54
SMC - 12 - 12N	3/4	3/4	15.74	1-1/16	1-1/8	24.38	21.84	40.38	50.54
SMC - 12 - 16N	3/4	1	15.74	1-3/8	1-1/8	24.38	21.84	46.99	57.15
SMC - 14 - 12N	7/8	3/4	15.74	1-3/16	1-1/4	25.90	21.84	40.38	50.54
SMC - 14 - 16N	7/8	1	18.28	1-3/8	1-1/4	25.90	21.84	46.99	57.15
SMC - 16 - 8N	1	1/2	11.93	1-3/8	1-1/2	31.24	26.41	45.21	57.40
SMC - 16 - 12N	1	3/4	15.74	1-3/8	1-1/2	31.24	26.41	45.21	57.40
SMC - 16 - 16N	1	1	22.35	1-3/8	1-1/2	31.24	26.41	50.03	62.23
SMC - 20 - 16N	1-1/4	1	22.35	1-3/4	1-7/8	41.15	38.86	55.12	77.22
SMC - 20 - 20N	1-1/4	1-1/4	27.69	1-3/4	1-7/8	41.15	38.86	55.12	77.22
SMC - 24 - 24N	1-1/2	1-1/2	34.04	2-1/8	2-1/4	50.04	45.21	61.72	88.90
SMC - 32 - 32N	2	2	45.97	2-3/4	3	67.56	62.74	76.20	113.54

- Dimensions and Drawings are for reference only and are subject to change without prior notice.  
 - Unless otherwise specified, all dimensions are in millimeters.  
 - Sizes, pressure classes, and end connections not listed are available upon request.  
 - Dimensions shown with SUPERLOK nuts finger-tight, where applicable.

# SMC

## Male Connector

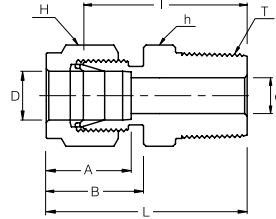

### Connects Fractional Tube To Female ISO Tapered Thread

Part No.	Tube OD D (inch)	T R (PT)	d Min	Width Across Flat		A	B	I	L
				h (inch)	H (inch)				
SMC - 2 - 2R	1/8	1/8	2.28	7/16	7/16	12.70	15.24	23.87	30.48
SMC - 2 - 4R	1/8	1/4	2.28	9/16	7/16	12.70	15.24	28.95	35.56
SMC - 4 - 2R	1/4	1/8	4.82	1/2	9/16	15.24	17.78	25.40	32.76
SMC - 4 - 4R	1/4	1/4	4.82	9/16	9/16	15.24	17.78	30.48	37.84
SMC - 4 - 6R	1/4	3/8	4.82	11/16	9/16	15.24	17.78	30.98	38.35
SMC - 4 - 8R	1/4	1/2	4.82	7/8	9/16	15.24	17.78	37.33	44.70
SMC - 5 - 2R	5/16	1/8	4.82	9/16	5/8	16.25	18.54	26.67	34.03
SMC - 5 - 4R	5/16	1/4	6.35	9/16	5/8	16.25	18.54	31.24	38.60
SMC - 6 - 2R	3/8	1/8	4.82	5/8	11/16	16.76	19.30	27.94	35.30
SMC - 6 - 4R	3/8	1/4	7.11	5/8	11/16	16.76	19.30	32.51	39.87
SMC - 6 - 6R	3/8	3/8	7.11	11/16	11/16	16.76	19.30	32.51	39.87
SMC - 6 - 8R	3/8	1/2	7.11	7/8	11/16	16.76	19.30	38.86	46.22
SMC - 8 - 4R	1/2	1/4	7.11	13/16	7/8	22.86	21.84	33.27	43.43
SMC - 8 - 6R	1/2	3/8	9.65	13/16	7/8	22.86	21.84	33.27	43.43
SMC - 8 - 8R	1/2	1/2	10.41	7/8	7/8	22.86	21.84	38.86	49.02
SMC - 8 - 12R	1/2	3/4	10.41	1-1/16	7/8	22.86	21.84	40.38	50.54
SMC - 12 - 12R	3/4	3/4	15.74	1-1/16	1-1/8	24.38	21.84	40.38	50.54
SMC - 16 - 16R	1	1	22.35	1-3/8	1-1/2	31.24	26.41	50.03	62.23

### Bored - Through Fittings for Thermocouples

SUPERLOK Bored-Through MALE CONNECTORS accommodate thermocouples or dip tubes.

To order suffix “-TM” to the Size designator. (Example : SU-8-TM, SMC-8-8N-TM-B)

Note - The root diameter of the pipe thread end of male connectors makes it impractical to bore through all male connectors.



- Dimensions and Drawings are for reference only and are subject to change without prior notice.
- Unless otherwise specified, all dimensions are in millimeters.
- Sizes, pressure classes, and end connections not listed are available upon request.
- Dimensions shown with SUPERLOK nuts finger-tight, where applicable.



**SMC**  
Male Connector

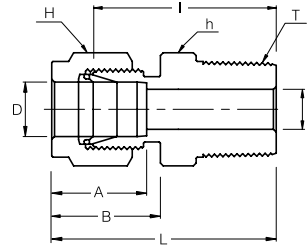

**Connects Metric Tube To Female NPT Thread**

Part No.	Tube OD D	T (NPT)	d Min	Width Across Flat		A	B	I	L
				h	H				
SMC - 2M - 2N	2	1/8	1.7	12	12	12.9	15.3	23.9	30.5
SMC - 3M - 2N	3	1/8	2.4	12	12	12.9	15.3	23.9	30.5
SMC - 3M - 4N	3	1/4	2.4	14	12	12.9	15.3	29.0	35.6
SMC - 4M - 2N	4	1/8	2.4	12	12	13.7	16.1	24.6	31.2
SMC - 4M - 4N	4	1/4	2.4	14	12	13.7	16.1	29.7	36.3
SMC - 6M - 2N	6	1/8	4.8	14	14	15.3	17.7	25.4	32.8
SMC - 6M - 4N	6	1/4	4.8	14	14	15.3	17.7	30.5	37.9
SMC - 6M - 6N	6	3/8	4.8	18	14	15.3	17.7	31.0	38.4
SMC - 6M - 8N	6	1/2	4.8	22	14	15.3	17.7	37.3	44.7
SMC - 8M - 2N	8	1/8	4.8	15	16	16.2	18.6	26.7	34.2
SMC - 8M - 4N	8	1/4	6.4	15	16	16.2	18.6	31.2	38.7
SMC - 8M - 6N	8	3/8	6.4	18	16	16.2	18.6	31.8	39.3
SMC - 8M - 8N	8	1/2	6.4	22	16	16.2	18.6	38.1	45.6
SMC - 10M - 2N	10	1/8	4.8	18	19	17.2	19.5	28.7	36.3
SMC - 10M - 4N	10	1/4	7.9	18	19	17.2	19.5	33.3	40.9
SMC - 10M - 6N	10	3/8	7.9	18	19	17.2	19.5	33.3	40.9
SMC - 10M - 8N	10	1/2	7.9	22	19	17.2	19.5	38.9	46.5
SMC - 12M - 2N	12	1/8	4.8	22	22	22.8	22.0	28.7	38.8
SMC - 12M - 4N	12	1/4	7.1	22	22	22.8	22.0	33.3	43.4
SMC - 12M - 6N	12	3/8	9.5	22	22	22.8	22.0	33.3	43.4
SMC - 12M - 8N	12	1/2	9.5	22	22	22.8	22.0	38.9	49.0
SMC - 12M - 12N	12	3/4	9.5	27	22	22.8	22.0	40.4	50.5
SMC - 14M - 4N	14	1/4	7.1	24	25	24.4	22.0	34.0	44.1
SMC - 14M - 6N	14	3/8	9.5	24	25	24.4	22.0	34.0	44.1
SMC - 14M - 8N	14	1/2	11.1	24	25	24.4	22.0	38.9	49.0
SMC - 16M - 6N	16	3/8	9.5	24	25	24.4	22.0	34.0	44.1
SMC - 16M - 8N	16	1/2	11.9	24	25	24.4	22.0	38.9	49.0
SMC - 16M - 12N	16	3/4	12.7	27	25	24.4	22.0	40.4	50.5
SMC - 18M - 8N	18	1/2	11.9	27	30	24.4	22.0	40.4	50.5
SMC - 18M - 12N	18	3/4	15.1	27	30	24.4	22.0	40.4	50.5
SMC - 20M - 8N	20	1/2	11.9	30	32	26.0	22.0	42.2	52.3
SMC - 20M - 12N	20	3/4	15.9	30	32	26.0	22.0	42.2	52.3
SMC - 22M - 12N	22	3/4	15.9	30	32	26.0	22.0	42.2	52.3
SMC - 22M - 16N	22	1	18.3	35	32	26.0	22.0	47.0	57.1
SMC - 25M - 12N	25	3/4	15.9	35	38	31.3	26.5	45.2	57.5
SMC - 25M - 16N	25	1	21.8	35	38	31.3	26.5	50.0	62.3
SMC - 28M - 16N	28	1	21.8	41	46	36.6	36.6	51.6	72.4
SMC - 28M - 20N	28	1-1/4	21.8	44.4	46	36.6	36.6	52.3	73.1
SMC - 30M - 20N	30	1-1/4	26.2	46	50	39.6	39.2	55.6	77.2
SMC - 32M - 20N	32	1-1/4	28.6	46	50	42.0	41.6	56.6	79.6
SMC - 38M - 24N	38	1-1/2	33.7	55	60	49.4	47.9	64.0	91.6

- Dimensions and Drawings are for reference only and are subject to change without prior notice.  
 - Unless otherwise specified, all dimensions are in millimeters.  
 - Sizes, pressure classes, and end connections not listed are available upon request.  
 - Dimensions shown with SUPERLOK nuts finger-tight, where applicable.

**SMC**  
Male Connector

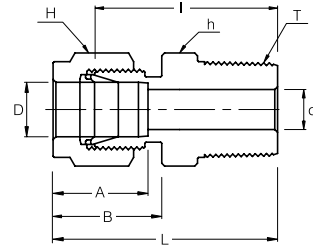

**Connects Metric Tube To Female ISO Tapered Thread**

Part No.	Tube OD D	T R (PT)	d Min	Width Across Flat		A	B	I	L
				h	H				
SMC - 2M - 2R	2	1/8	1.7	12	12	12.9	15.3	23.9	30.5
SMC - 3M - 2R	3	1/8	2.4	12	12	12.9	15.3	23.9	30.5
SMC - 3M - 4R	3	1/4	2.4	14	12	12.9	15.3	29.0	35.6
SMC - 4M - 2R	4	1/8	2.4	12	12	13.7	16.1	24.6	31.2
SMC - 4M - 4R	4	1/4	2.4	14	12	13.7	16.1	29.7	36.3
SMC - 6M - 2R	6	1/8	4.8	14	14	15.3	17.7	25.4	32.8
SMC - 6M - 4R	6	1/4	4.8	14	14	15.3	17.7	30.5	37.9
SMC - 6M - 6R	6	3/8	4.8	18	14	15.3	17.7	31.0	38.4
SMC - 6M - 8R	6	1/2	4.8	22	14	15.3	17.7	37.3	44.7
SMC - 8M - 2R	8	1/8	4.8	15	16	16.2	18.6	26.7	34.2
SMC - 8M - 4R	8	1/4	6.4	15	16	16.2	18.6	31.2	38.7
SMC - 8M - 6R	8	3/8	6.4	18	16	16.2	18.6	31.8	39.3
SMC - 8M - 8R	8	1/2	6.4	22	16	16.2	18.6	38.1	45.6
SMC - 10M - 2R	10	1/8	4.8	18	19	17.2	19.5	28.7	36.3
SMC - 10M - 4R	10	1/4	7.9	18	19	17.2	19.5	33.3	40.9
SMC - 10M - 6R	10	3/8	7.9	18	19	17.2	19.5	33.3	40.9
SMC - 10M - 8R	10	1/2	7.9	22	19	17.2	19.5	38.9	46.5
SMC - 12M - 4R	12	1/4	7.1	22	22	22.8	22.0	33.3	43.4
SMC - 12M - 6R	12	3/8	9.5	22	22	22.8	22.0	33.3	43.4
SMC - 12M - 8R	12	1/2	9.5	22	22	22.8	22.0	38.9	49.0
SMC - 12M - 12R	12	3/4	9.5	27	22	22.8	22.0	40.4	50.5
SMC - 15M - 8R	15	1/2	11.9	24	25	24.4	22.0	38.9	49.0
SMC - 16M - 4R	16	1/4	7.1	24	25	24.4	22.0	34.0	44.1
SMC - 16M - 6R	16	3/8	9.5	24	25	24.4	22.0	34.0	44.1
SMC - 16M - 8R	16	1/2	11.9	24	25	24.4	22.0	38.9	49.0
SMC - 16M - 12R	16	3/4	12.7	27	25	24.4	22.0	40.4	50.5
SMC - 18M - 8R	18	1/2	11.9	27	30	24.4	22.0	40.4	50.5
SMC - 18M - 12R	18	3/4	15.1	27	30	24.4	22.0	40.4	50.5
SMC - 20M - 8R	20	1/2	11.9	30	32	26.0	22.0	42.2	52.3
SMC - 20M - 12R	20	3/4	15.9	30	32	26.0	22.0	42.2	52.3
SMC - 22M - 12R	22	3/4	15.9	30	32	26.0	22.0	42.2	52.3
SMC - 22M - 16R	22	1	18.3	35	32	26.0	22.0	47.0	57.1
SMC - 25M - 12R	25	3/4	15.9	35	38	31.3	26.5	45.2	57.5
SMC - 25M - 16R	25	1	21.8	35	38	31.3	26.5	50.0	62.3
SMC - 28M - 16R	28	1	21.8	41	46	36.6	36.6	51.6	72.4
SMC - 28M - 20R	28	1-1/4	21.8	44.4	46	36.6	36.6	52.3	73.1
SMC - 30M - 20R	30	1-1/4	26.2	46	50	39.6	39.2	55.6	77.2
SMC - 32M - 20R	32	1-1/4	28.6	46	50	42.0	41.6	56.6	79.6
SMC - 38M - 24R	38	1-1/2	33.7	55	60	49.4	47.9	64.0	91.6

- Dimensions and Drawings are for reference only and are subject to change without prior notice.  
 - Unless otherwise specified, all dimensions are in millimeters.  
 - Sizes, pressure classes, and end connections not listed are available upon request.  
 - Dimensions shown with SUPERLOK nuts finger-tight, where applicable.

**SMC - GM**

Male Connector  
For Metal Gasket Seal

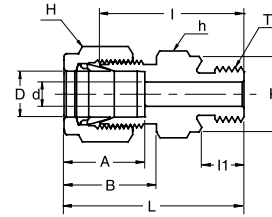
**Connects Metric Tube To Female ISO Parallel Thread**

Part No.	Tube OD D	T G (PF)	d Min	Width Across Flat		A	B	I	I1	L	K
				h	H						
SMC - 3M - 2GM	3	1/8	2.4	14	12	12.9	15.3	23.4	8.0	30.0	14.0
SMC - 3M - 4GM	3	1/4	2.4	19	12	12.9	15.3	28.7	12.0	35.3	18.0
SMC - 4M - 2GM	4	1/8	2.4	14	12	13.7	16.1	24.1	8.0	30.7	14.0
SMC - 6M - 2GM	6	1/8	4.0	14	14	15.3	17.7	24.9	8.0	32.3	14.0
SMC - 6M - 4GM	6	1/4	4.8	19	14	15.3	17.7	30.2	12.0	37.6	18.0
SMC - 6M - 6GM	6	3/8	4.8	22	14	15.3	17.7	31.5	12.0	38.9	22.0
SMC - 6M - 8GM	6	1/2	4.8	27	14	15.3	17.7	37.3	14.0	44.7	26.0
SMC - 8M - 2GM	8	1/8	4.0	15	16	16.2	18.6	25.7	8.0	33.2	14.0
SMC - 8M - 4GM	8	1/4	6.4	19	16	16.2	18.6	31.0	12.0	38.5	18.0
SMC - 8M - 6GM	8	3/8	6.4	22	16	16.2	18.6	32.3	12.0	39.8	22.0
SMC - 8M - 8GM	8	1/2	6.4	27	16	16.2	18.6	38.1	14.0	45.6	26.0
SMC - 10M - 4GM	10	1/4	5.9	19	19	17.2	19.5	31.8	12.0	39.4	18.0
SMC - 10M - 6GM	10	3/8	7.9	22	19	17.2	19.5	33.0	12.0	40.6	22.0
SMC - 10M - 8GM	10	1/2	7.9	27	19	17.2	19.5	38.9	14.0	46.5	26.0
SMC - 12M - 4GM	12	1/4	5.9	22	22	22.8	22.0	32.5	12.0	42.6	18.0
SMC - 12M - 6GM	12	3/8	7.9	22	22	22.8	22.0	33.0	12.0	43.1	22.0
SMC - 12M - 8GM	12	1/2	9.5	27	22	22.8	22.0	38.9	14.0	49.0	26.0
SMC - 12M - 12GM	12	3/4	9.5	35	22	22.8	22.0	42.7	16.0	52.8	32.0
SMC - 15M - 8GM	15	1/2	11.9	27	25	24.4	22.0	38.9	14.0	49.0	26.0
SMC - 16M - 6GM	16	3/8	7.9	24	25	24.4	22.0	33.8	12.0	43.9	22.0
SMC - 16M - 8GM	16	1/2	11.9	27	25	24.4	22.0	38.9	14.0	49.0	26.0
SMC - 18M - 8GM	18	1/2	11.9	27	30	24.4	22.0	38.9	14.0	49.0	26.0
SMC - 18M - 12GM	18	3/4	15.1	35	30	24.4	22.0	42.7	16.0	52.8	32.0
SMC - 20M - 8GM	20	1/2	11.9	30	32	26.0	22.0	40.4	14.0	50.5	26.0
SMC - 20M - 12GM	20	3/4	15.9	35	32	26.0	22.0	42.7	16.0	52.8	32.0
SMC - 22M - 12GM	22	3/4	15.9	35	32	26.0	22.0	42.7	16.0	52.8	32.0
SMC - 22M - 16GM	22	1	18.3	41	32	26.0	22.0	45.2	18.0	55.3	39.0
SMC - 25M - 12GM	25	3/4	15.9	35	38	31.3	26.5	45.2	16.0	57.5	32.0
SMC - 25M - 16GM	25	1	19.8	41	38	31.3	26.5	47.8	18.0	60.1	39.0

\* See page 6 for Explanation of ISO Pipe Thread.

- Dimensions and Drawings are for reference only and are subject to change without prior notice.
- Unless otherwise specified, all dimensions are in millimeters.
- Sizes, pressure classes, and end connections not listed are available upon request.
- Dimensions shown with SUPERLOK nuts finger-tight, where applicable.

# SGMC

Male Connector  
For Bonded Washer Seal

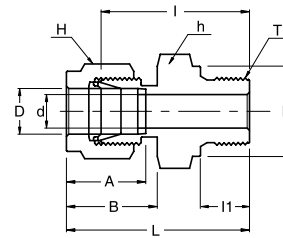

## Connects Metric Tubes To Female ISO Parallel Thread

Part No.	Tube OD D	T G (PF)	d Min	Width Across Flat		A	B	I	I1	L	K
				h	H						
SGMC - 3M - 2G	3	1/8	2.4	14	12	12.9	15.3	23.4	8.0	30.0	14.0
SGMC - 3M - 4G	3	1/4	2.4	19	12	12.9	15.3	28.7	12.0	35.3	18.0
SGMC - 4M - 2G	4	1/8	2.4	14	12	13.7	16.1	24.1	8.0	30.7	14.0
SGMC - 6M - 2G	6	1/8	4.0	14	14	15.3	17.7	24.9	8.0	32.3	14.0
SGMC - 6M - 4G	6	1/4	4.8	19	14	15.3	17.7	30.2	12.0	37.6	18.0
SGMC - 6M - 6G	6	3/8	4.8	22	14	15.3	17.7	31.5	12.0	38.9	22.0
SGMC - 6M - 8G	6	1/2	4.8	27	14	15.3	17.7	37.3	14.0	44.7	26.0
SGMC - 8M - 2G	8	1/8	4.0	15	16	16.2	18.6	25.7	8.0	33.2	14.0
SGMC - 8M - 4G	8	1/4	6.4	19	16	16.2	18.6	31.0	12.0	38.5	18.0
SGMC - 8M - 6G	8	3/8	6.4	22	16	16.2	18.6	32.3	12.0	39.8	22.0
SGMC - 8M - 8G	8	1/2	6.4	27	16	16.2	18.6	38.1	14.0	45.6	26.0
SGMC - 10M - 4G	10	1/4	5.9	19	19	17.2	19.5	31.8	12.0	39.4	18.0
SGMC - 10M - 6G	10	3/8	7.9	22	19	17.2	19.5	33.0	12.0	40.6	22.0
SGMC - 10M - 8G	10	1/2	7.9	27	19	17.2	19.5	38.9	14.0	46.5	26.0
SGMC - 12M - 4G	12	1/4	5.9	22	22	22.8	22.0	32.5	12.0	42.6	18.0
SGMC - 12M - 6G	12	3/8	7.9	22	22	22.8	22.0	33.0	12.0	43.1	22.0
SGMC - 12M - 8G	12	1/2	9.5	27	22	22.8	22.0	38.9	14.0	49.0	26.0
SGMC - 12M - 12G	12	3/4	9.5	35	22	22.8	22.0	42.7	16.0	52.8	32.0
SGMC - 16M - 6G	16	3/8	7.9	24	25	24.4	22.0	33.8	12.0	43.9	22.0
SGMC - 16M - 8G	16	1/2	11.9	27	25	24.4	22.0	38.9	14.0	49.0	26.0
SGMC - 18M - 8G	18	1/2	11.9	27	30	24.4	22.0	38.9	14.0	49.0	26.0
SGMC - 18M - 12G	18	3/4	15.1	35	30	24.4	22.0	42.7	16.0	52.8	32.0
SGMC - 20M - 8G	20	1/2	11.9	30	32	26.0	22.0	40.4	14.0	50.5	26.0
SGMC - 20M - 12G	20	3/4	15.9	35	32	26.0	22.0	42.7	16.0	52.8	32.0
SGMC - 22M - 12G	22	3/4	15.9	35	32	26.0	22.0	42.7	16.0	52.8	32.0
SGMC - 22M - 16G	22	1	18.3	41	32	26.0	22.0	45.2	18.0	55.3	39.0
SGMC - 25M - 12G	25	3/4	15.9	35	38	31.3	26.5	45.2	16.0	57.5	32.0
SGMC - 25M - 16G	25	1	19.8	41	38	31.3	26.5	47.8	18.0	60.1	39.0

\* See page 6 for Explanation of ISO Pipe Thread.

- Dimensions and Drawings are for reference only and are subject to change without prior notice.
- Unless otherwise specified, all dimensions are in millimeters.
- Sizes, pressure classes, and end connections not listed are available upon request.
- Dimensions shown with SUPERLOK nuts finger-tight, where applicable.

# SFC

## Female Connector

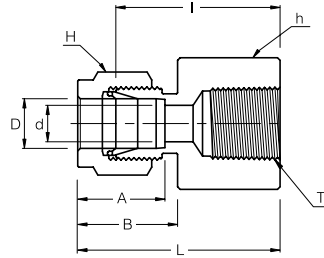

### Connects Fractional Tubes To Male NPT Thread

Part No.	Tube OD D (inch)	T* (NPT)	d Min	Width Across Flat		A	B	I	L
				h (inch)	H (inch)				
SFC - 2 - 2N	1/8	1/8	2.28	9/16	7/16	12.70	15.24	22.09	28.70
SFC - 2 - 4N	1/8	1/4	2.28	3/4	7/16	12.70	15.24	26.92	33.52
SFC - 3 - 2N	3/16	1/8	3.04	9/16	1/2	13.71	16.00	23.11	29.71
SFC - 4 - 2N	1/4	1/8	4.82	9/16	9/16	15.24	17.78	23.87	31.24
SFC - 4 - 4N	1/4	1/4	4.82	3/4	9/16	15.24	17.78	28.44	35.81
SFC - 4 - 6N	1/4	3/8	4.82	7/8	9/16	15.24	17.78	30.22	37.59
SFC - 4 - 8N	1/4	1/2	4.82	1-1/16	9/16	15.24	17.78	35.05	42.41
SFC - 5 - 2N	5/16	1/8	6.35	9/16	5/8	16.25	18.54	24.63	32.00
SFC - 5 - 4N	5/16	1/4	6.35	3/4	5/8	16.25	18.54	29.46	36.83
SFC - 6 - 2N	3/8	1/8	7.11	5/8	11/16	16.76	19.30	25.40	32.76
SFC - 6 - 4N	3/8	1/4	7.11	3/4	11/16	16.76	19.30	30.22	37.59
SFC - 6 - 6N	3/8	3/8	7.11	7/8	11/16	16.76	19.30	31.75	39.11
SFC - 6 - 8N	3/8	1/2	7.11	1-1/16	11/16	16.76	19.30	36.57	43.94
SFC - 6 - 12N	3/8	3/4	7.11	1-5/16	11/16	16.76	19.30	40.38	47.75
SFC - 8 - 4N	1/2	1/4	10.41	13/16	7/8	22.86	21.84	30.22	40.38
SFC - 8 - 6N	1/2	3/8	10.41	7/8	7/8	22.86	21.84	31.75	41.91
SFC - 8 - 8N	1/2	1/2	10.41	1-1/16	7/8	22.86	21.84	36.57	46.73
SFC - 8 - 12N	1/2	3/4	10.41	1-5/16	7/8	22.86	21.84	38.10	48.26
SFC -10 - 6N	5/8	3/8	12.70	15/16	1	24.38	21.84	31.75	41.91
SFC -10 - 8N	5/8	1/2	12.70	1-1/16	1	24.38	21.84	36.57	46.73
SFC -12 - 8N	3/4	1/2	15.74	1-1/16	1-1/8	24.38	21.84	36.57	46.73
SFC -12 - 12N	3/4	3/4	15.74	1-5/16	1-1/8	24.38	21.84	38.10	48.26
SFC -14 - 12N	7/8	3/4	18.28	1-5/16	1-1/4	25.90	21.84	39.62	49.78
SFC -16 - 12N	1	3/4	22.35	1-3/8	1-1/2	31.24	26.41	41.14	53.34
SFC -16 - 16N	1	1	22.35	1-5/8	1-1/2	31.24	26.41	50.03	62.23

- Dimensions and Drawings are for reference only and are subject to change without prior notice.  
 - Unless otherwise specified, all dimensions are in millimeters.  
 - Sizes, pressure classes, and end connections not listed are available upon request.  
 - Dimensions shown with SUPERLOK nuts finger-tight, where applicable.

# SFC

## Female Connector

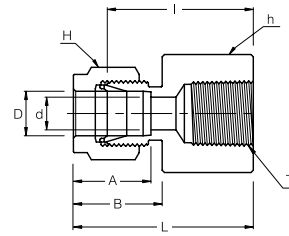

### Connects Metric Tubes To Male ISO Tapered Thread

Part No.	Tube OD D	T* R (PT)	d Min	Width Across Flat		A	B	I	L
				h	H				
SFC - 3M - 2R	3	1/8	2.4	14	12	12.9	15.3	22.1	28.7
SFC - 3M - 4R	3	1/4	2.4	19	12	12.9	15.3	26.9	33.5
SFC - 4M - 2R	4	1/8	2.4	14	12	13.7	16.1	23.1	29.7
SFC - 6M - 2R	6	1/8	4.8	14	14	15.3	17.7	23.9	31.3
SFC - 6M - 4R	6	1/4	4.8	19	14	15.3	17.7	28.4	35.8
SFC - 6M - 6R	6	3/8	4.8	22	14	15.3	17.7	30.2	37.6
SFC - 6M - 8R	6	1/2	4.8	27	14	15.3	17.7	35.1	42.5
SFC - 8M - 2R	8	1/8	6.4	15	16	16.2	18.6	24.6	32.1
SFC - 8M - 4R	8	1/4	6.4	19	16	16.2	18.6	29.5	37.0
SFC - 8M - 6R	8	3/8	6.4	22	16	16.2	18.6	31.0	38.5
SFC - 8M - 8R	8	1/2	6.4	27	16	16.2	18.6	35.8	43.3
SFC - 10M - 2R	10	1/8	7.9	18	19	17.2	19.5	25.4	33.0
SFC - 10M - 4R	10	1/4	7.9	19	19	17.2	19.5	30.2	37.8
SFC - 10M - 6R	10	3/8	7.9	22	19	17.2	19.5	31.8	39.4
SFC - 10M - 8R	10	1/2	7.9	27	19	17.2	19.5	36.6	44.2
SFC - 12M - 2R	12	1/8	8.3	22	22	22.8	22.0	25.4	35.5
SFC - 12M - 4R	12	1/4	9.5	22	22	22.8	22.0	30.2	40.3
SFC - 12M - 6R	12	3/8	9.5	22	22	22.8	22.0	31.8	41.9
SFC - 12M - 8R	12	1/2	9.5	27	22	22.8	22.0	36.6	46.7
SFC - 12M - 12R	12	3/4	9.5	35	22	22.8	22.0	38.9	49.0
SFC - 15M - 8R	15	1/2	11.9	27	25	24.4	22.0	36.6	46.7
SFC - 16M - 8R	16	1/2	12.7	27	25	24.4	22.0	36.8	46.9
SFC - 20M - 8R	20	1/2	15.9	30	32	26.0	22.0	37.8	47.9
SFC - 20M - 12R	20	3/4	15.9	35	32	26.0	22.0	39.6	49.7
SFC - 22M - 12R	22	3/4	18.3	35	32	26.0	22.0	39.6	49.7
SFC - 22M - 16R	22	1	18.3	41	32	26.0	22.0	47.8	57.9
SFC - 25M - 12R	25	3/4	21.8	35	38	31.3	26.5	41.1	53.4
SFC - 25M - 16R	25	1	21.8	41	38	31.3	26.5	50.0	62.3

- Dimensions and Drawings are for reference only and are subject to change without prior notice.  
 - Unless otherwise specified, all dimensions are in millimeters.  
 - Sizes, pressure classes, and end connections not listed are available upon request.  
 - Dimensions shown with SUPERLOK nuts finger-tight, where applicable.



# SGC

## Gauge Connector

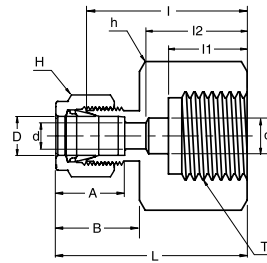

### Connects Fractional Tubes To ISO Parallel Thread

Part No.	Tube OD D (inch)	T G (PF)	d Min	d1	Width Across Flat		A	B	I	I1	I2	L
					h (inch)	H (inch)						
SGC - 4 - 4G	1/4	1/4	4.82	5.58	3/4	9/16	15.24	17.78	30.22	13.00	17.00	37.59
SGC - 4 - 6G	1/4	3/8	4.82	6.60	15/16	9/16	15.24	17.78	30.22	14.20	20.30	37.59
SGC - 4 - 8G	1/4	1/2	4.82	6.60	1-1/16	9/16	15.24	17.78	36.07	18.80	24.90	43.43
SGC - 5 - 4G	5/16	1/4	5.58	-	3/4	5/8	16.25	18.54	30.98	13.00	-	38.35
SGC - 5 - 8G	5/16	1/2	7.11	-	1-1/16	5/8	16.25	18.54	33.53	18.80	-	40.89
SGC - 6 - 4G	3/8	1/4	5.58	-	3/4	11/16	16.76	19.30	31.75	13.00	-	39.12
SGC - 6 - 6G	3/8	3/8	6.60	-	15/16	11/16	16.76	19.30	31.24	14.20	-	38.61
SGC - 6 - 8G	3/8	1/2	7.11	-	1-1/16	11/16	16.76	19.30	34.54	18.80	-	41.91
SGC - 8 - 4G	1/2	1/4	5.58	-	7/8	7/8	22.86	21.84	31.80	13.00	-	41.95
SGC - 8 - 6G	1/2	3/8	6.60	-	15/16	7/8	22.86	21.84	34.29	14.20	-	44.45
SGC - 8 - 8G	1/2	1/2	7.11	7.11	1-1/16	7/8	22.86	21.84	38.10	18.80	-	48.26

### Connects Metric Tubes To ISO Parallel Thread

Part No.	Tube OD D (inch)	T G (PF)	d Min	d1	Width Across Flat		A	B	I	I1	I2	L
					h	H						
SGC - 3M - 4G	3	1/4	2.4	5.5	19	12	12.9	15.3	28.7	13	17	35.3
SGC - 6M - 4G	6	1/4	4.8	5.5	19	14	15.3	17.7	30.2	13	17	37.6
SGC - 6M - 6G	6	3/8	4.8	6.5	24	14	15.3	17.7	30.2	14	20	37.6
SGC - 6M - 8G	6	1/2	4.8	7.0	27	14	15.3	17.7	36.1	19	25	43.5
SGC - 8M - 4G	8	1/4	5.5	5.5	19	16	16.2	18.6	31.0	13	-	38.5
SGC - 8M - 6G	8	3/8	6.5	6.5	24	16	16.2	18.6	28.7	14	-	36.2
SGC - 8M - 8G	8	1/2	7.0	7.0	27	16	16.2	18.6	33.5	19	-	41.0
SGC - 10M - 4G	10	1/4	5.5	5.5	19	19	17.2	19.5	31.8	13	-	39.4
SGC - 10M - 6G	10	3/8	6.5	6.5	24	19	17.2	19.5	31.2	14	-	38.8
SGC - 10M - 8G	10	1/2	7.0	7.0	27	19	17.2	19.5	34.5	19	-	42.1
SGC - 12M - 4G	12	1/4	5.5	5.5	22	22	22.8	22.0	31.8	13	-	41.9
SGC - 12M - 6G	12	3/8	6.5	6.5	24	22	22.8	22.0	34.3	14	-	44.4
SGC - 12M - 8G	12	1/2	7.0	7.0	27	22	22.8	22.0	38.1	19	-	48.2
SGC - 20M - 8G	20	1/2	7.0	7.0	30	32	26.0	22.0	44.2	19	-	54.3
SGC - 22M - 8G	22	1/2	7.0	7.0	30	32	26.0	22.0	44.2	19	-	54.3

\* See page 6 for Explanation of ISO Pipe Thread.

- Dimensions and Drawings are for reference only and are subject to change without prior notice.
- Unless otherwise specified, all dimensions are in millimeters.
- Sizes, pressure classes, and end connections not listed are available upon request.
- Dimensions shown with SUPERLOK nuts finger-tight, where applicable.

# SMCB

## Bulkhead Male Connector

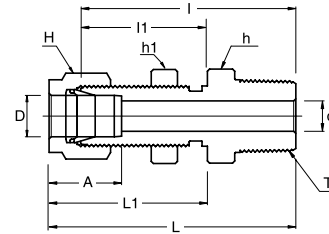

### Connects Fractional Tubes To Female NPT Thread

Part No.	Tube OD D (inch)	T* (NPT)	d Min	Width Across Flat			A	I	I1	L	L1	Panel Hole Drill Size	Panel Max. Thickness
				h (inch)	h1 (inch)	H (inch)							
SMCB - 2 - 2N	1/8	1/8	2.28	1/2	1/2	7/16	12.70	39.87	24.63	46.48	31.24	8.33	12.70
SMCB - 4 - 2N	1/4	1/8	4.82	5/8	5/8	9/16	15.24	42.16	26.16	49.53	33.52	11.50	10.16
SMCB - 4 - 4N	1/4	1/4	4.82	5/8	5/8	9/16	15.24	46.73	26.16	54.10	33.52	11.50	10.16
SMCB - 6 - 4N	3/8	1/4	7.11	3/4	3/4	11/16	16.76	50.03	29.46	57.40	36.83	14.68	11.17
SMCB - 6 - 6N	3/8	3/8	7.11	3/4	3/4	11/16	16.76	50.03	29.46	57.40	36.83	14.68	11.17
SMCB - 6 - 8N	3/8	1/2	7.11	7/8	3/4	11/16	16.76	56.38	29.46	63.75	36.83	14.68	11.17
SMCB - 8 - 6N	1/2	3/8	9.65	15/16	15/16	7/8	22.86	53.08	31.75	63.24	41.91	19.44	12.70
SMCB - 8 - 8N	1/2	1/2	10.41	15/16	15/16	7/8	22.86	58.67	31.75	68.83	41.91	19.44	12.70
SMCB - 12 - 12N	3/4	3/4	15.74	1-3/16	1-3/16	1-1/8	24.38	66.04	37.33	76.20	47.49	25.79	16.76
SMCB - 16 - 16N	1	1	22.35	1-5/8	1-5/8	1-1/2	31.24	81.02	45.21	93.21	57.40	33.73	19.05

- Dimensions and Drawings are for reference only and are subject to change without prior notice.  
 - Unless otherwise specified, all dimensions are in millimeters.  
 - Sizes, pressure classes, and end connections not listed are available upon request.  
 - Dimensions shown with SUPERLOK nuts finger-tight, where applicable.

## SFCB

### Bulkhead Female Connector

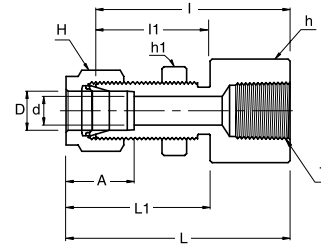

#### Connects Fractional Tubes To Male NPT Thread

Part No.	Tube OD D (inch)	T* (NPT)	d Min	Width Across Flat			A	I	I1	L	L1	Panel Hole Drill Size	Panel Max. Thickness
				h (inch)	h1 (inch)	H (inch)							
SFCB - 2 - 2N	1/8	1/8	2.28	9/16	1/2	7/16	12.70	38.10	24.63	44.70	31.24	8.33	12.70
SFCB - 4 - 2N	1/4	1/8	4.82	5/8	5/8	9/16	15.24	39.62	26.16	46.99	33.52	11.50	10.16
SFCB - 4 - 4N	1/4	1/4	4.82	3/4	5/8	9/16	15.24	44.45	26.16	51.81	33.52	11.50	10.16
SFCB - 6 - 4N	3/8	1/4	7.11	3/4	3/4	11/16	16.76	47.75	29.46	55.11	36.83	14.68	11.17
SFCB - 8 - 6N	1/2	3/8	10.41	15/16	15/16	7/8	22.86	51.56	31.75	61.72	41.91	19.44	12.70
SFCB - 8 - 8N	1/2	1/2	10.41	1-1/16	15/16	7/8	22.86	56.38	31.75	66.54	41.91	19.44	12.70
SFCB - 12 - 12N	3/4	3/4	15.74	1-1/4	1-3/16	1-1/8	24.38	63.60	37.33	73.51	47.49	25.79	16.76

#### Connects Metric Tubes To Male NPT Thread

Part No.	Tube OD D (inch)	T* (NPT)	d Min	Width Across Flat			A	I	I1	L	L1	Panel Hole Drill Size	Panel Max. Thickness
				h	h1	H							
SFCB - 6M - 2N	6	1/8	4.8	15.8	15.8	14	15.3	39.6	27.7	46.90	35.00	11.5	10.2
SFCB - 6M - 4N	6	1/4	4.8	19.0	16.0	14	15.3	44.4	26.2	51.80	33.60	11.5	10.2
SFCB - 8M - 4N	8	1/4	6.3	19.0	17.4	16	16.2	46.7	28.4	53.85	35.55	13.1	11.2
SFCB - 12M - 8N	12	1/2	9.5	27.0	24.0	22	22.8	56.4	31.8	66.50	41.90	19.5	12.7

- Dimensions and Drawings are for reference only and are subject to change without prior notice.
- Unless otherwise specified, all dimensions are in millimeters.
- Sizes, pressure classes, and end connections not listed are available upon request.
- Dimensions shown with SUPERLOK nuts finger-tight, where applicable.

**SUE**  
Union Elbow

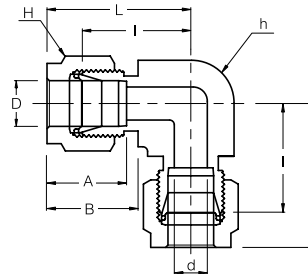

**Connects Fractional Tubes**

Part No.	Tube OD D (inch)	d Min	Width Across Flat		A	B	I	L
			h (inch)	H (inch)				
SUE - 1	1/16	1.27	3/8	5/16	8.63	10.92	14.00	18.03
SUE - 2	1/8	2.28	3/8	7/16	12.70	15.24	15.74	22.35
SUE - 3	3/16	3.04	1/2	1/2	13.71	16.00	18.54	25.14
SUE - 4	1/4	4.82	1/2	9/16	15.24	17.78	20.10	27.40
SUE - 5	5/16	6.35	5/8	5/8	16.25	18.54	22.35	29.71
SUE - 6	3/8	7.11	5/8	11/16	16.76	19.30	23.11	30.48
SUE - 8	1/2	10.41	13/16	7/8	22.86	21.84	25.90	36.06
SUE - 10	5/8	12.70	15/16	1	24.38	21.84	27.94	38.10
SUE - 12	3/4	15.74	1-1/16	1-1/8	24.38	21.84	29.71	39.87
SUE - 14	7/8	18.28	1-3/8	1-1/4	25.90	21.84	34.54	44.70
SUE - 16	1	22.35	1-3/8	1-1/2	31.24	26.41	36.83	49.02
SUE - 20	1-1/4	27.69	1-11/16	1-7/8	41.15	38.86	44.45	66.55
SUE - 24	1-1/2	34.04	2	2-1/4	50.04	45.21	50.80	77.98
SUE - 32	2	45.97	2-3/4	3	67.56	62.74	69.85	107.19

**Connects Metric Tubes**

Part No.	Tube OD D	d Min	Width Across Flat		A	B	I	L
			h	H				
SUE 2M	2	1.7	9.5	12	12.9	15.3	15.7	22.3
SUE - 3M	3	2.4	9.5	12	12.9	15.3	15.7	22.3
SUE - 4M	4	2.4	12.7	12	13.7	16.1	18.8	25.4
SUE - 6M	6	4.8	12.7	14	15.3	17.7	19.6	27.0
SUE - 8M	8	6.4	15.9	16	16.2	18.6	22.4	29.9
SUE - 10M	10	7.9	17.5	19	17.2	19.5	23.9	31.5
SUE - 12M	12	9.5	20.6	22	22.8	22.0	25.9	36.0
SUE - 15M	15	11.9	23.8	25	24.4	22.0	27.9	38.8
SUE - 16M	16	12.7	23.8	25	24.4	22.0	27.9	38.0
SUE - 18M	18	15.1	27.0	30	24.4	22.0	29.7	39.8
SUE - 20M	20	15.9	34.9	32	26.0	22.0	34.5	44.6
SUE - 22M	22	18.3	34.9	32	26.0	22.0	34.5	44.6
SUE - 25M	25	21.8	34.9	38	31.3	26.5	36.8	49.1
SUE - 28M	28	21.8	41	46	36.6	36.6	43.2	64.0
SUE - 30M	30	26.2	42.9	50	39.6	39.2	48.3	69.9
SUE - 32M	32	28.6	42.9	50	42.0	41.6	49.3	72.3
SUE - 38M	38	33.7	55	60	49.4	47.9	56.4	84.0

- Dimensions and Drawings are for reference only and are subject to change without prior notice.
- Unless otherwise specified, all dimensions are in millimeters.
- Sizes, pressure classes, and end connections not listed are available upon request.
- Dimensions shown with SUPERLOK nuts finger-tight, where applicable.

# SHUE

## 45° Union Elbow

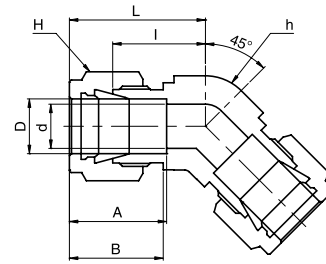

Part No.	Tube OD D (inch)	d Min	Width Across Flat		A	B	I	L
			h (inch)	H (inch)				
SHUE - 2	1/8	2.28	1/2	7/16	12.70	15.00	15.70	22.00
SHUE - 4	1/4	4.82	1/2	9/16	15.24	17.78	17.27	24.63
SHUE - 6	3/8	7.11	5/8	11/16	15.76	19.30	20.57	27.94
SHUE - 8	1/2	10.41	13/16	7/8	22.86	21.84	21.84	32.00
SHUE - 12	3/4	15.74	1-1/16	1-1/8	24.38	21.88	21.30	31.48
SHUE - 16	1	22.35	1-3/8	1-1/2	31.24	26.44	28.20	40.39

- Dimensions and Drawings are for reference only and are subject to change without prior notice.  
 - Unless otherwise specified, all dimensions are in millimeters.  
 - Sizes, pressure classes, and end connections not listed are available upon request.  
 - Dimensions shown with SUPERLOK nuts finger-tight, where applicable.

# SME

## Male Elbow

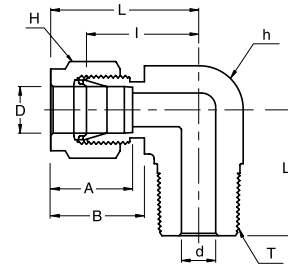

### Connects Metric Tubes To Female NPT Thread

Part No.	Tube OD D	T (NPT)	d Min	Width Across Flat		A	B	I	L	L1
				h	H					
SME - 3M - 2N	3	1/8	2.4	12.7	12	12.9	15.3	17.0	23.6	17.8
SME - 3M - 4N	3	1/4	2.4	12.7	12	12.9	15.3	18.0	24.6	23.4
SME - 4M - 2N	4	1/8	2.4	12.7	12	13.7	16.1	18.8	25.4	18.8
SME - 4M - 4N	4	1/4	2.4	12.7	12	13.7	16.1	18.8	25.4	23.4
SME - 6M - 2N	6	1/8	4.8	12.7	14	15.3	17.7	19.6	27.0	18.8
SME - 6M - 4N	6	1/4	4.8	12.7	14	15.3	17.7	19.6	27.0	23.4
SME - 6M - 6N	6	3/8	4.8	15.9	14	15.3	17.7	22.4	29.8	26.2
SME - 6M - 8N	6	1/2	4.8	20.6	14	15.3	17.7	24.4	31.8	33.0
SME - 8M - 2N	8	1/8	4.8	14.3	16	16.2	18.6	21.3	28.8	19.8
SME - 8M - 4N	8	1/4	6.4	14.3	16	16.2	18.6	21.3	28.8	24.4
SME - 8M - 6N	8	3/8	6.4	15.9	16	16.2	18.6	23.1	30.6	26.2
SME - 8M - 8N	8	1/2	6.4	20.6	16	16.2	18.6	25.1	32.6	33.0
SME - 10M - 2N	10	1/8	4.8	17.5	19	17.2	19.5	23.9	31.5	21.6
SME - 10M - 4N	10	1/4	7.1	17.5	19	17.2	19.5	23.9	31.5	26.2
SME - 10M - 6N	10	3/8	7.9	17.5	19	17.2	19.5	23.9	31.5	26.2
SME - 10M - 8N	10	1/2	7.9	20.6	19	17.2	19.5	25.9	33.5	33.0
SME - 12M - 4N	12	1/4	7.1	20.6	22	22.8	22.0	25.9	36.0	28.2
SME - 12M - 6N	12	3/8	9.5	20.6	22	22.8	22.0	25.9	36.0	28.2
SME - 12M - 8N	12	1/2	9.5	20.6	22	22.8	22.0	25.9	36.0	33.0
SME - 12M - 12N	12	3/4	9.5	27.0	22	22.8	22.0	29.7	39.8	36.8
SME - 16M - 6N	16	3/8	9.5	23.8	25	24.4	22.0	27.9	38.0	30.2
SME - 16M - 8N	16	1/2	11.9	23.8	25	24.4	22.0	27.9	38.0	35.1
SME - 16M - 12N	16	3/4	12.7	27.0	25	24.4	22.0	29.7	39.8	36.8
SME - 18M - 8N	18	1/2	11.9	27.0	30	24.4	22.0	29.7	39.8	36.8
SME - 18M - 12N	18	3/4	15.1	27.0	30	24.4	22.0	29.7	39.8	36.8
SME - 20M - 8N	20	1/2	11.9	34.9	32	26.0	22.0	34.5	44.6	41.7
SME - 20M - 12N	20	3/4	15.9	34.9	32	26.0	22.0	34.5	44.6	41.7
SME - 22M - 12N	22	3/4	15.9	34.9	32	26.0	22.0	34.5	44.6	41.7
SME - 22M - 16N	22	1	18.3	34.9	32	26.0	22.0	34.5	44.6	46.5
SME - 25M - 12N	25	3/4	15.9	34.9	38	31.3	26.5	36.8	49.1	41.7
SME - 25M - 16N	25	1	21.8	34.9	38	31.3	26.5	36.8	49.1	46.5
SME - 30M - 20N	30	1-1/4	26.2	42.9	50	39.6	39.2	48.3	69.9	53.1
SME - 32M - 20N	32	1-1/4	27.8	42.9	50	42.0	41.6	49.3	72.3	53.1
SME - 38M - 24N	38	1-1/2	33.7	55	60	49.4	47.9	56.4	84.0	60.4

- Dimensions and Drawings are for reference only and are subject to change without prior notice.
- Unless otherwise specified, all dimensions are in millimeters.
- Sizes, pressure classes, and end connections not listed are available upon request.
- Dimensions shown with SUPERLOK nuts finger-tight, where applicable.



# SME

## Male Elbow

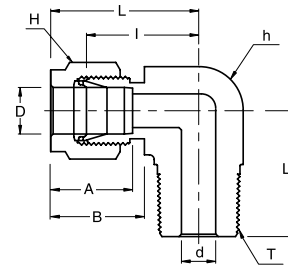

### Connects Metric Tubes To Female ISO Tapered Thread

Part No.	Tube OD D	T R (PT)	d Min	Width Across Flat		A	B	I	L	L1
				h	H					
SME - 3M - 2R	3	1/8	2.4	12.7	12	12.9	15.3	17.0	23.6	17.8
SME - 3M - 4R	3	1/4	2.4	12.7	12	12.9	15.3	18.0	24.6	23.4
SME - 4M - 2R	4	1/8	2.4	12.7	12	13.7	16.1	18.8	25.4	18.8
SME - 4M - 4R	4	1/4	2.4	12.7	12	13.7	16.1	18.8	25.4	23.4
SME - 6M - 2R	6	1/8	4.8	12.7	14	15.3	17.7	19.6	27.0	18.8
SME - 6M - 4R	6	1/4	4.8	12.7	14	15.3	17.7	19.6	27.0	23.4
SME - 6M - 6R	6	3/8	4.8	15.9	14	15.3	17.7	22.4	29.8	26.2
SME - 6M - 8R	6	1/2	4.8	20.6	14	15.3	17.7	24.4	31.8	33.0
SME - 8M - 2R	8	1/8	4.8	14.3	16	16.2	18.6	21.3	28.8	19.8
SME - 8M - 4R	8	1/4	6.4	14.3	16	16.2	18.6	21.3	28.8	24.4
SME - 8M - 6R	8	3/8	6.4	15.9	16	16.2	18.6	23.1	30.6	26.2
SME - 8M - 8R	8	1/2	6.4	20.6	16	16.2	18.6	25.1	32.6	33.0
SME - 10M - 4R	10	1/4	7.1	17.5	19	17.2	19.5	23.9	31.5	26.2
SME - 10M - 6R	10	3/8	7.9	17.5	19	17.2	19.5	23.9	31.5	26.2
SME - 10M - 8R	10	1/2	7.9	20.6	19	17.2	19.5	25.9	33.5	33.0
SME - 12M - 2R	12	1/8	4.8	20.6	22	22.8	22.0	25.9	36.0	23.6
SME - 12M - 4R	12	1/4	7.1	20.6	22	22.8	22.0	25.9	36.0	28.2
SME - 12M - 6R	12	3/8	9.5	20.6	22	22.8	22.0	25.9	36.0	28.2
SME - 12M - 8R	12	1/2	9.5	20.6	22	22.8	22.0	25.9	36.0	33.0
SME - 12M - 12R	12	3/4	9.5	27.0	22	22.8	22.0	29.7	39.8	36.8
SME - 16M - 6R	16	3/8	9.5	23.8	25	24.4	22.0	27.9	38.0	30.2
SME - 16M - 8R	16	1/2	11.9	23.8	25	24.4	22.0	27.9	38.0	35.1
SME - 18M - 8R	18	1/2	11.9	27.0	30	24.4	22.0	29.7	39.8	36.8
SME - 18M - 12R	18	3/4	15.1	27.0	30	24.4	22.0	29.7	39.8	36.8
SME - 20M - 8R	20	1/2	11.9	34.9	32	26.0	22.0	34.5	44.6	41.7
SME - 20M - 12R	20	3/4	15.9	34.9	32	26.0	22.0	34.5	44.6	41.7
SME - 22M - 12R	22	3/4	15.9	34.9	32	26.0	22.0	34.5	44.6	41.7
SME - 22M - 16R	22	1	18.3	34.9	32	26.0	22.0	34.5	44.6	46.5
SME - 25M - 12R	25	3/4	15.9	34.9	38	31.3	26.5	36.8	49.1	41.7
SME - 25M - 16R	25	1	21.8	34.9	38	31.3	26.5	36.8	49.1	46.5

- Dimensions and Drawings are for reference only and are subject to change without prior notice.  
 - Unless otherwise specified, all dimensions are in millimeters.  
 - Sizes, pressure classes, and end connections not listed are available upon request.  
 - Dimensions shown with SUPERLOK nuts finger-tight, where applicable.

# SME

## Male Elbow

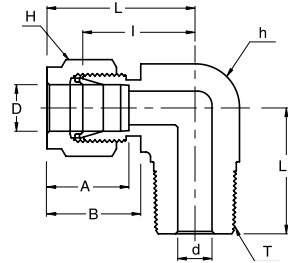

### Connects Fractional Tube To Female NPT Thread

Part No.	Tube OD D (inch)	T (NPT)	d Min	Width Across Flat		A	B	I	L	L1
				h (inch)	H (inch)					
SME - 2 - 2N	1/8	1/8	2.28	1/2	7/16	12.70	15.24	18.00	24.30	18.80
SME - 2 - 4N	1/8	1/4	2.28	1/2	7/16	12.70	15.24	18.00	24.30	23.36
SME - 3 - 2N	3/16	1/8	3.04	1/2	1/2	13.71	16.00	18.79	25.40	18.79
SME - 3 - 4N	3/16	1/4	3.04	1/2	1/2	13.71	16.00	18.79	25.40	23.36
SME - 4 - 2N	1/4	1/8	4.82	1/2	9/16	15.24	17.78	19.55	26.92	18.79
SME - 4 - 4N	1/4	1/4	4.82	1/2	9/16	15.24	17.78	19.55	26.92	23.36
SME - 4 - 6N	1/4	3/8	4.82	5/8	9/16	15.24	17.78	22.35	29.71	26.16
SME - 4 - 8N	1/4	1/2	4.82	13/16	9/16	15.24	17.78	24.38	31.75	33.02
SME - 5 - 2N	5/16	1/8	4.82	9/16	5/8	16.25	18.54	21.33	28.70	19.81
SME - 5 - 4N	5/16	1/4	6.35	9/16	5/8	16.25	18.54	21.33	28.70	24.38
SME - 5 - 6N	5/16	3/8	6.35	11/16	5/8	16.25	18.54	23.11	30.48	26.16
SME - 6 - 2N	3/8	1/8	4.82	5/8	11/16	16.76	19.30	23.11	30.48	20.82
SME - 6 - 4N	3/8	1/4	7.11	5/8	11/16	16.76	19.30	23.11	30.48	25.40
SME - 6 - 6N	3/8	3/8	7.11	5/8	11/16	16.76	19.30	23.87	31.24	26.16
SME - 6 - 8N	3/8	1/2	7.11	13/16	11/16	16.76	19.30	25.90	33.27	33.02
SME - 6 - 12N	3/8	3/4	7.11	1-1/16	11/16	16.76	19.30	29.71	37.08	36.83
SME - 8 - 4N	1/2	1/4	7.11	13/16	7/8	22.86	21.84	25.90	36.06	28.19
SME - 8 - 6N	1/2	3/8	9.65	13/16	7/8	22.86	21.84	25.90	36.06	28.19
SME - 8 - 8N	1/2	1/2	10.41	13/16	7/8	22.86	21.84	25.90	36.06	33.02
SME - 8 - 12N	1/2	3/4	10.41	1-1/16	7/8	22.86	21.84	29.71	39.87	36.83
SME - 10 - 6N	5/8	3/8	9.65	15/16	1	24.38	21.84	27.94	38.10	30.22
SME - 10 - 8N	5/8	1/2	11.93	15/16	1	24.38	21.84	27.94	38.10	35.10
SME - 10 - 12N	5/8	3/4	12.70	1-1/16	1	24.38	21.84	29.71	39.87	36.83
SME - 12 - 8N	3/4	1/2	11.93	1-1/16	1-1/8	24.38	21.84	29.71	39.87	36.83
SME - 12 - 12N	3/4	3/4	15.74	1-1/16	1-1/8	24.38	21.84	29.71	39.87	36.83
SME - 14 - 12N	7/8	3/4	15.74	1-3/8	1-1/4	25.90	21.84	34.54	44.70	41.65
SME - 16 - 12N	1	3/4	15.74	1-3/8	1-1/2	31.24	26.41	36.83	49.02	41.65
SME - 16 - 16N	1	1	22.35	1-3/8	1-1/2	31.24	26.41	36.83	49.02	46.48
SME - 20 - 20N	1-1/4	1-1/4	27.69	1-11/16	1-7/8	41.15	38.86	44.45	66.55	47.75
SME - 24 - 24N	1-1/2	1-1/2	34.04	2	2-1/4	50.04	45.21	50.80	77.98	60.45
SME - 32 - 32N	2	2	45.97	2-3/4	3	67.56	62.74	69.85	107.19	70.61

- Dimensions and Drawings are for reference only and are subject to change without prior notice.  
 - Unless otherwise specified, all dimensions are in millimeters.  
 - Sizes, pressure classes, and end connections not listed are available upon request.  
 - Dimensions shown with SUPERLOK nuts finger-tight, where applicable.

## SME

### Male Elbow

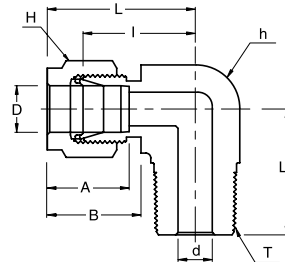

#### Connects Fractional Tubes To Female ISO Tapered Thread

Part No.	Tube OD D (inch)	T R (PT)	d Min	Width Across Flat		A	B	I	L	L1
				h (inch)	H (inch)					
SME - 4 - 2R	1/4	1/8	4.82	1/2	9/16	15.24	17.78	19.55	26.92	18.79
SME - 4 - 4R	1/4	1/4	4.82	1/2	9/16	15.24	17.78	19.55	26.92	23.36
SME - 4 - 6R	1/4	3/8	4.82	5/8	9/16	15.24	17.78	22.35	29.71	26.16
SME - 4 - 8R	1/4	1/2	4.82	13/16	9/16	15.24	17.78	24.38	31.75	33.02
SME - 5 - 4R	5/16	1/4	6.35	9/16	5/8	16.25	18.54	21.33	28.70	24.38
SME - 6 - 4R	3/8	1/4	7.11	5/8	11/16	16.76	19.30	23.11	30.48	25.40
SME - 6 - 6R	3/8	3/8	7.11	5/8	11/16	16.76	19.30	23.87	31.24	26.16
SME - 8 - 6R	1/2	3/8	9.65	13/16	7/8	22.86	21.84	25.91	36.07	28.20
SME - 8 - 8R	1/2	1/2	10.41	13/16	7/8	22.86	21.84	25.91	36.07	33.02

## SHME

### 45° Male Elbow

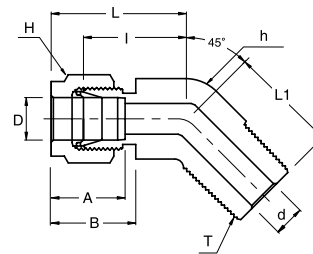

#### Connects Fractional Tubes To Female NPT Thread

Part No.	Tube OD D (inch)	T* (NPT)	d Min	Width Across Flat		A	B	I	L	L1
				h (inch)	H (inch)					
SHME - 4 - 2N	1/4	1/8	4.82	1/2	9/16	15.24	17.78	17.27	24.63	16.51
SHME - 4 - 4N	1/4	1/4	4.82	1/2	9/16	15.24	17.78	17.27	24.63	21.08
SHME - 6 - 2N	3/8	1/8	4.82	5/8	11/16	16.76	19.30	20.57	27.94	18.28
SHME - 6 - 4N	3/8	1/4	7.11	5/8	11/16	16.76	19.30	20.57	27.94	22.86
SHME - 6 - 6N	3/8	3/8	7.11	13/16	11/16	16.76	19.30	21.84	29.21	24.13
SHME - 8 - 6N	1/2	3/8	9.65	13/16	7/8	22.86	21.84	21.84	32.00	24.13
SHME - 8 - 8N	1/2	1/2	10.41	13/16	7/8	22.86	21.84	21.84	32.00	28.95

- Dimensions and Drawings are for reference only and are subject to change without prior notice.
- Unless otherwise specified, all dimensions are in millimeters.
- Sizes, pressure classes, and end connections not listed are available upon request.
- Dimensions shown with SUPERLOK nuts finger-tight, where applicable.

## SPHME

### 45° Positionable Male Elbow

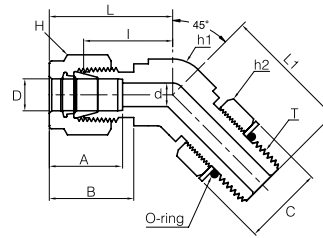

#### Connects Fractional Tubes To SAE/MS Straight Thread

Part No.	Tube OD D (inch)	T (U)	d Min	Width Across Flat			A	B	I	L	L1	C
				h1(inch)	h2(inch)	H(inch)						
SPHME - 4 - 4U	1/4	7/16-20	4.83	1/2	9/16	9/16	15.24	17.78	18.29	25.64	25.65	16.51
SPHME - 6 - 6U	3/8	9/16-18	7.11	5/8	11/16	11/16	16.76	19.30	20.57	27.94	28.19	20.07
SPHME - 8 - 8U	1/2	3/4-16	10.41	13/16	7/8	7/8	22.86	21.84	21.84	32.00	32.26	25.65
SPHME - 12 - 12U	3/4	1-1/16-12	15.75	1-1/8	1-1/4	1-1/8	24.38	24.84	29.72	39.88	47.24	36.58
SPHME - 16 - 16U	1	1-5/16-12	22.35	1-3/8	1-1/2	1-1/2	31.24	26.42	35.31	47.50	50.55	43.94

## SPME

### Positionable Male Elbow

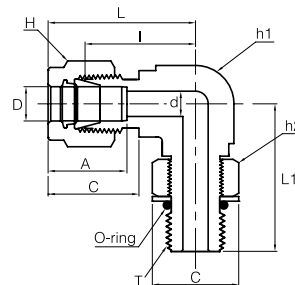

#### Connects Fractional Tubes To SAE/MS Straight Thread

Part No.	Tube OD D (inch)	T (U)	d Min	Width Across Flat			A	B	I	L	L1	C
				h1(inch)	h2(inch)	H(inch)						
SPME - 4 - 4U	1/4	7/16-20	4.83	1/2	9/16	9/16	15.24	17.78	21.08	28.45	28.45	16.51
SPME - 4 - 6U	1/4	9/16-18	4.83	5/8	11/16	9/16	15.24	17.78	23.11	30.48	32.26	20.07
SPME - 5 - 5U	5/16	1/2-20	5.84	9/16	5/8	5/8	16.26	18.54	23.60	30.23	29.46	18.29
SPME - 6 - 6U	3/8	9/16-18	7.11	5/8	11/16	11/16	16.76	19.30	24.64	32.00	32.26	20.07
SPME - 6 - 8U	3/8	3/4-16	7.11	13/16	7/8	11/16	16.76	19.30	27.43	34.80	37.85	25.65
SPME - 8 - 8U	1/2	3/4-16	10.41	13/16	7/8	7/8	22.86	21.84	27.43	37.59	37.85	25.65
SPME - 10 - 10U	5/8	7/8-14	12.70	15/16	1	1	24.38	21.84	27.90	39.62	43.43	29.46
SPME - 12 - 12U	3/4	1-1/16-12	15.75	1-1/16	1-1/4	1-1/8	24.38	21.84	29.70	41.40	48.77	36.58
SPME - 14 - 14U	7/8	3/16-12	18.29	1-3/16	1-3/8	1-1/4	25.91	21.84	33.02	43.18	50.55	40.39
SPME - 16 - 16U	1	1-5/16-12	22.35	1-3/8	1-1/2	1-1/2	31.24	26.42	36.80	50.55	53.59	43.94
SPME - 20 - 20U	1-1/4	1-5/8-12	27.69	1-11/16	1-7/8	1-7/8	41.15	38.86	45.72	67.82	58.17	54.86
SPME - 24 - 24U	1-1/2	1-7/8-12	34.04	2	2-1/8	2-1/4	50.04	45.21	50.80	77.98	60.45	62.23
SPME - 32 - 32U	2	2-1/2-12	45.97	2-3/4	2-3/4	3	67.56	62.74	69.85	107.19	71.63	80.26

- Dimensions and Drawings are for reference only and are subject to change without prior notice.
- Unless otherwise specified, all dimensions are in millimeters.
- Sizes, pressure classes, and end connections not listed are available upon request.
- Dimensions shown with SUPERLOK nuts finger-tight, where applicable.

# SPME

## Positionable Male Elbow

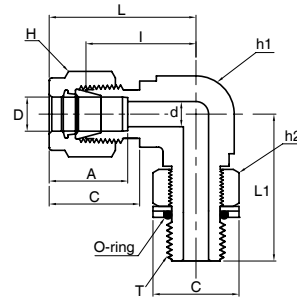

### Connects Fractional Tubes To Female ISO Parallel Thread

Part No.	Tube OD D (inch)	T (PF)	d Min	Width Across Flat			A	B	I	L	L1	C
				h1(inch)	h2(inch)	H(inch)						
SPME - 4 - 2G	1/4	1/8	4.06	1/2	9/16	9/16	15.24	17.78	19.56	26.92	26.42	17.27
SPME - 4 - 4G	1/4	1/4	4.83	5/8	3/4	9/16	15.24	17.78	21.59	28.96	32.26	22.86
SPME - 6 - 4G	3/8	1/4	5.84	5/8	3/4	11/16	16.76	19.30	23.60	30.48	32.26	22.86
SPME - 6 - 6G	3/8	3/8	7.11	13/16	7/8	11/16	16.76	19.30	25.91	33.27	37.08	26.42
SPME - 8 - 4G	1/2	1/4	5.84	13/16	3/4	7/8	22.86	21.84	25.91	36.07	35.05	26.42
SPME - 8 - 6G	1/2	3/8	7.87	13/16	7/8	7/8	22.86	21.84	25.91	36.07	37.08	22.86
SPME - 8 - 8G	1/2	1/2	10.41	15/16	1-1/16	7/8	22.86	21.84	27.94	38.10	43.43	26.42
SPME - 10 - 8G	5/8	1/2	11.94	15/16	1-1/16	1	24.38	21.84	27.94	38.10	43.43	32.00
SPME - 12 - 8G	3/4	1/2	11.94	1-1/16	1-1/16	1-1/8	24.38	21.84	29.72	39.88	45.21	32.00
SPME - 12 - 12G	3/4	3/4	15.75	1-1/16	1-3/8	1-1/8	24.38	21.84	29.72	39.88	48.77	41.15
SPME - 16 - 12G	1	3/4	15.75	1-3/8	1-3/8	1-1/2	31.24	26.42	36.83	49.02	53.34	41.15
SPME - 16 - 16G	1	1	19.81	1-3/8	1-5/8	1-1/2	31.24	26.42	36.83	49.02	53.59	48.51

### Connects Metric Tubes To Female ISO Parallel Thread

Part No.	Tube OD D	T (PF)	d Min	Width Across Flat			A	B	I	L	L1	C
				h1(inch)	h2(inch)	H						
SPME - 6M - 2G	6	1/8	4.0	1/2	9/16	14	15.3	17.7	19.6	27.0	26.4	17.3
SPME - 6M - 4G	6	1/4	4.8	5/8	3/4	14	15.3	17.7	21.6	29.0	32.3	22.9
SPME - 8M - 2G	8	1/8	4.0	9/16	9/16	16	16.2	18.6	21.3	28.8	27.4	17.3
SPME - 8M - 4G	8	1/4	5.9	5/8	3/4	16	16.2	18.6	22.4	29.9	32.2	22.9
SPME - 10M - 4G	10	1/4	5.9	13/16	3/4	19	17.2	19.5	25.9	33.5	35.0	22.9
SPME - 10M - 6G	10	3/8	7.9	13/16	7/8	19	17.2	19.5	25.9	33.5	37.1	26.4
SPME - 12M - 4G	12	1/4	5.9	13/16	3/4	22	22.8	22.0	25.9	36.0	35.0	22.9
SPME - 12M - 6G	12	3/8	7.9	13/16	7/8	22	22.8	22.0	25.9	36.0	37.1	26.4
SPME - 12M - 8G	12	1/2	9.5	15/16	1-1/16	22	22.8	22.0	27.9	38.0	43.4	32.0
SPME - 12M - 12G	12	3/4	9.5	1-1/16	1-3/8	22	22.8	22.0	29.7	39.8	48.8	41.1

- Dimensions and Drawings are for reference only and are subject to change without prior notice.  
 - Unless otherwise specified, all dimensions are in millimeters.  
 - Sizes, pressure classes, and end connections not listed are available upon request.  
 - Dimensions shown with SUPERLOK nuts finger-tight, where applicable.

**SFE**  
Female Elbow

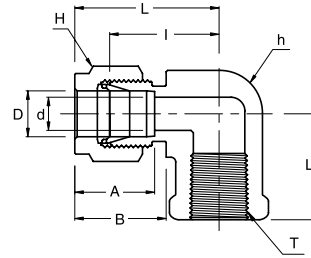

**Connects Fractional Tubes To Male NPT Thread**

Part No.	Tube OD D (inch)	T* (NPT)	d Min	Width Across Flat		A	B	I	L	L1
				h (inch)	H (inch)					
SFE - 2 - 2N	1/8	1/8	2.28	1/2	7/16	12.70	15.24	18.03	24.63	23.40
SFE - 2 - 4N	1/8	1/4	2.28	11/16	7/16	12.70	15.24	20.82	27.43	29.00
SFE - 3 - 2N	3/16	1/8	3.04	1/2	1/2	13.71	16.00	18.79	25.40	23.40
SFE - 4 - 2N	1/4	1/8	4.82	1/2	9/16	15.24	17.78	19.55	26.92	23.40
SFE - 4 - 4N	1/4	1/4	4.82	11/16	9/16	15.24	17.78	22.35	29.71	29.00
SFE - 4 - 6N	1/4	3/8	4.82	13/16	9/16	15.24	17.78	24.38	31.75	22.35
SFE - 4 - 8N	1/4	1/2	4.82	1	9/16	15.24	17.78	27.17	34.54	37.00
SFE - 5 - 2N	5/16	1/8	6.35	9/16	5/8	16.25	18.54	21.33	28.70	19.05
SFE - 5 - 4N	5/16	1/4	6.35	11/16	5/8	16.25	18.54	23.11	30.48	29.00
SFE - 6 - 2N	3/8	1/8	7.11	5/8	11/16	16.76	19.30	23.11	30.48	19.05
SFE - 6 - 4N	3/8	1/4	7.11	11/16	11/16	16.76	19.30	23.87	31.24	29.00
SFE - 6 - 6N	3/8	3/8	7.11	13/16	11/16	16.76	19.30	25.90	33.27	22.35
SFE - 6 - 8N	3/8	1/2	7.11	1	11/16	16.76	19.30	28.70	36.06	37.00
SFE - 8 - 4N	1/2	1/4	10.41	13/16	7/8	22.86	21.84	25.90	36.06	22.35
SFE - 8 - 6N	1/2	3/8	10.41	13/16	7/8	22.86	21.84	25.90	36.06	22.35
SFE - 8 - 8N	1/2	1/2	10.41	1	7/8	22.86	21.84	28.70	38.86	37.00
SFE - 10 - 6N	5/8	3/8	12.70	15/16	1	24.38	21.84	27.94	38.10	22.35
SFE - 10 - 8N	5/8	1/2	12.70	1-1/16	1	24.38	21.84	29.71	39.87	28.44
SFE - 12 - 8N	3/4	1/2	15.74	1-1/16	1-1/8	24.38	21.84	29.71	39.87	28.44
SFE - 12 - 12N	3/4	3/4	15.74	1-3/8	1-1/8	24.38	21.84	34.54	44.70	31.75
SFE - 14 - 12N	7/8	3/4	18.28	1-3/8	1-1/4	25.90	21.84	34.54	44.70	31.75
SFE - 16 - 12N	1	3/4	22.35	1-3/8	1-1/2	31.24	26.41	36.83	49.02	31.75
SFE - 16 - 16N	1	1	22.35	1-11/16	1-1/2	31.24	26.41	41.40	53.59	38.10

**Connects Metric Tubes To Male NPT Thread**

Part No.	Tube OD D	T* (NPT)	d Min	Width Across Flat		A	B	I	L	L1
				h	H					
SFE - 6M - 4N	6	1/4	4.8	17.46	14	15.3	17.7	22.4	29.8	22.40
SFE - 6M - 6N	6	3/8	4.8	20.63	14	15.3	17.7	24.4	31.7	22.40
SFE - 6M - 8N	6	1/2	4.8	25.40	14	15.3	17.7	27.2	34.6	37.00
SFE - 8M - 4N	8	1/4	6.4	17.46	16	16.2	18.6	23.1	30.6	29.00
SFE - 8M - 8N	8	1/2	6.4	25.40	16	16.2	18.6	28.0	35.2	37.00
SFE - 10M - 4N	10	1/4	7.9	17.46	19	17.2	19.5	25.9	33.5	29.00
SFE - 10M - 6N	10	3/8	7.9	20.63	19	17.2	19.5	25.9	33.5	22.40
SFE - 10M - 8N	10	1/2	7.9	25.40	19	17.2	19.5	28.7	36.1	37.00
SFE - 12M - 6N	12	3/8	9.5	20.63	22	22.8	22.0	25.9	36.2	22.35
SFE - 12M - 8N	12	1/2	9.5	25.40	22	22.8	22.0	28.7	38.8	37.00

- Dimensions and Drawings are for reference only and are subject to change without prior notice.
- Unless otherwise specified, all dimensions are in millimeters.
- Sizes, pressure classes, and end connections not listed are available upon request.
- Dimensions shown with SUPERLOK nuts finger-tight, where applicable.



**SUT**  
Union Tee

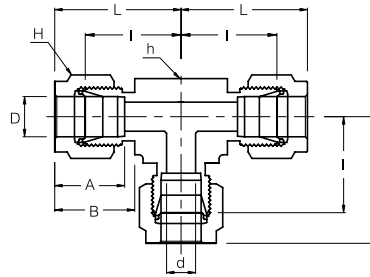

**Connects Fractional Tubes**

Part No.	Tube OD D (inch)	d Min	Width Across Flat		A	B	I	L
			h (inch)	H (inch)				
SUT - 1	1/16	1.27	3/8	5/16	8.63	10.92	14.00	18.03
SUT - 2	1/8	2.28	3/8	7/16	12.70	15.24	15.80	22.35
SUT - 3	3/16	3.04	1/2	1/2	13.71	16.00	18.54	25.14
SUT - 4	1/4	4.82	1/2	9/16	15.24	17.78	20.10	27.40
SUT - 5	5/16	6.35	5/8	5/8	16.25	18.54	22.35	29.71
SUT - 6	3/8	7.11	5/8	11/16	16.76	19.30	23.11	30.48
SUT - 8	1/2	10.41	13/16	7/8	22.86	21.84	25.90	36.06
SUT - 10	5/8	12.70	1	1	24.38	21.84	28.70	38.86
SUT - 12	3/4	15.74	1-1/16	1-1/8	24.38	21.84	29.71	39.87
SUT - 14	7/8	18.28	1-3/8	1-1/4	25.90	21.84	34.54	44.70
SUT - 16	1	22.35	1-3/8	1-1/2	31.24	26.41	36.83	49.02
SUT - 20	1-1/4	27.69	1-11/16	1-7/8	41.15	38.86	44.45	66.55
SUT - 24	1-1/2	34.04	2	2-1/4	50.04	45.21	50.80	77.98
SUT - 32	2	45.97	2-3/4	3	67.56	62.74	69.85	107.19

**Connects Metric Tubes**

Part No.	Tube OD D	d Min	Width Across Flat		A	B	I	L
			h	H				
SUT - 2M	2	1.7	9.5	12	12.9	15.3	15.7	22.3
SUT - 3M	3	2.4	9.5	12	12.9	15.3	15.7	22.3
SUT - 4M	4	2.4	12.7	12	13.7	16.1	18.8	25.4
SUT - 6M	6	4.8	12.7	14	15.3	17.7	19.6	27.0
SUT - 8M	8	6.4	15.9	16	16.2	18.6	22.4	29.9
SUT - 10M	10	7.9	17.5	19	17.2	19.5	23.9	31.5
SUT - 12M	12	9.5	20.6	22	22.8	22.0	25.9	36.0
SUT - 15M	15	11.9	25.4	25	24.4	22.0	28.7	38.8
SUT - 16M	16	12.7	25.4	25	24.4	22.0	28.7	38.8
SUT - 18M	18	15.1	27.0	30	24.4	22.0	29.7	38.8
SUT - 20M	20	15.9	34.9	32	26.0	22.0	34.5	44.6
SUT - 22M	22	18.3	34.9	32	26.0	22.0	34.5	44.6
SUT - 25M	25	21.8	34.9	38	31.3	26.5	36.8	49.1
SUT - 28M	28	21.8	41	46	36.6	36.6	43.2	64.0
SUT - 30M	30	26.2	42.9	50	39.6	39.2	48.3	69.9
SUT - 32M	32	28.6	42.9	50	42.0	41.6	49.3	72.3
SUT - 38M	38	33.7	55	60	49.4	47.9	56.4	84.0

- Dimensions and Drawings are for reference only and are subject to change without prior notice.  
 - Unless otherwise specified, all dimensions are in millimeters.  
 - Sizes, pressure classes, and end connections not listed are available upon request.  
 - Dimensions shown with SUPERLOK nuts finger-tight, where applicable.

# SRUT

## Reducing Union Tee

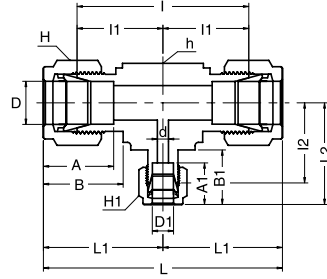

### Connects Fractional Tubes

Part No.	Tube OD		d Min	Width Across Flat			A	A1	B	B1	I	I1	I2	L	L1	L2
	D (inch)	D1 (inch)		h (inch)	H (inch)	H1 (inch)										
SRUT - 6 - 4	3/8	1/4	4.82	5/8	11/16	9/16	16.76	15.24	19.30	17.78	46.22	23.11	21.59	60.96	30.48	28.95
SRUT - 8 - 4	1/2	1/4	4.82	13/16	7/8	9/16	22.86	15.24	21.84	17.78	51.81	25.90	24.38	72.13	36.06	31.75
SRUT - 8 - 6	1/2	3/8	7.11	13/16	7/8	11/16	22.86	16.76	21.84	19.30	51.81	25.90	25.90	72.13	36.06	33.27
SRUT - 10 - 6	5/8	3/8	7.11	1	1	11/16	24.38	16.76	21.84	19.30	57.40	28.70	28.70	77.72	38.86	36.06
SRUT - 12 - 6	3/4	3/8	7.11	1 1/16	1 1/8	11/16	24.38	16.76	21.84	19.30	59.43	29.71	29.71	79.75	39.87	37.08
SRUT - 12 - 8	3/4	1/2	10.41	1 1/16	1 1/8	7/8	24.38	22.86	21.84	21.84	59.43	29.71	29.71	79.75	39.87	39.87
SRUT - 16 - 6	1	3/8	7.11	1 3/8	1 1/2	11/16	31.24	16.76	26.41	19.30	73.66	36.83	34.54	98.04	49.02	41.91
SRUT - 16 - 8	1	1/2	10.41	1 3/8	1 1/2	7/8	31.24	21.84	26.41	22.86	73.66	36.83	34.54	98.04	49.02	44.70
SRUT - 16 - 12	1	3/4	15.74	1 3/8	1 1/2	1 1/8	31.24	24.38	26.41	21.84	73.66	36.83	34.54	98.04	49.02	44.70

- Dimensions and Drawings are for reference only and are subject to change without prior notice.  
 - Unless otherwise specified, all dimensions are in millimeters.  
 - Sizes, pressure classes, and end connections not listed are available upon request.  
 - Dimensions shown with SUPERLOK nuts finger-tight, where applicable.

**SMBT**

## Male Branch Tee

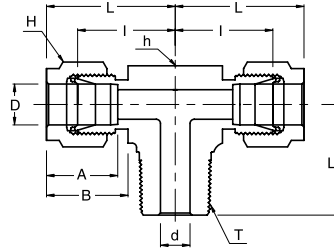
**Connects Fractional Tubes To Female NPT Thread**

Part No.	Tube OD D (inch)	T * (NPT)	d Min	Width Across Flat		A	B	I	L	L1
				h (inch)	H (inch)					
SMBT - 2 - 2N	1/8	1/8	2.28	1/2	7/16	12.70	15.24	18.30	24.91	18.90
SMBT - 2 - 4N	1/8	1/4	2.28	1/2	7/16	12.70	15.24	18.03	24.63	23.36
SMBT - 3 - 2N	3/16	1/8	3.04	1/2	1/2	13.71	16.00	17.78	25.40	18.79
SMBT - 4 - 2N	1/4	1/8	4.82	1/2	9/16	15.24	17.78	19.55	26.92	18.79
SMBT - 4 - 4N	1/4	1/4	4.82	1/2	9/16	15.24	17.78	19.55	26.92	23.36
SMBT - 5 - 2N	5/16	1/8	4.82	5/8	5/8	16.25	18.54	22.35	29.71	20.82
SMBT - 6 - 4N	3/8	1/4	7.11	5/8	11/16	16.76	19.30	23.11	30.48	25.40
SMBT - 6 - 6N	3/8	3/8	7.11	5/8	11/16	16.76	19.30	23.10	30.48	28.19
SMBT - 8 - 6N	1/2	3/8	9.65	13/16	7/8	22.86	21.84	25.90	36.06	28.19
SMBT - 8 - 8N	1/2	1/2	10.41	13/16	7/8	22.86	21.84	25.90	36.06	33.02
SMBT - 10 - 8N	5/8	1/2	11.93	1	1	24.38	21.84	28.70	38.86	35.81
SMBT - 12 - 12N	3/4	3/4	15.74	1-1/16	1-1/8	24.38	21.84	29.71	39.87	36.83

**Connects Metric Tubes To Female ISO Tapered Thread**

Part No.	Tube OD D	T * R (PT)	d Min	Width Across Flat		A	B	I	L	L1
				h	H					
SMBT - 3M - 2R	3	1/8	2.4	12.7	12	12.9	15.3	17.0	23.6	17.8
SMBT - 3M - 4R	3	1/4	2.4	12.7	12	12.9	15.3	18.0	24.6	23.4
SMBT - 4M - 2R	4	1/8	2.4	12.7	12	13.7	16.1	18.8	25.4	18.8
SMBT - 6M - 2R	6	1/8	4.8	12.7	14	15.3	17.7	19.6	27.0	18.8
SMBT - 6M - 4R	6	1/4	4.8	12.7	14	15.3	17.7	19.6	27.0	23.4
SMBT - 8M - 2R	8	1/8	4.8	15.9	16	16.2	18.6	22.4	29.9	20.8
SMBT - 8M - 4R	8	1/4	6.4	15.9	16	16.2	18.6	22.4	29.9	25.4
SMBT - 10M - 4R	10	1/4	7.1	17.5	19	17.2	19.5	23.9	31.5	28.2
SMBT - 10M - 6R	10	3/8	7.9	17.5	19	17.2	19.5	23.9	31.5	28.2
SMBT - 12M - 4R	12	1/4	7.1	20.6	22	22.8	22.0	25.9	36.0	28.2
SMBT - 12M - 6R	12	3/8	9.5	20.6	22	22.8	22.0	25.9	36.0	28.2
SMBT - 12M - 8R	12	1/2	9.5	20.6	22	22.8	22.0	25.9	36.0	33.0
SMBT - 16M - 6R	16	3/8	9.5	25.4	25	24.4	22.0	27.9	38.0	30.2
SMBT - 16M - 8R	16	1/2	11.9	25.4	25	24.4	22.0	27.9	38.0	35.1
SMBT - 20M - 12R	20	3/4	15.9	31.8	32	26.0	22.0	34.5	44.6	41.7

- Dimensions and Drawings are for reference only and are subject to change without prior notice.
- Unless otherwise specified, all dimensions are in millimeters.
- Sizes, pressure classes, and end connections not listed are available upon request.
- Dimensions shown with SUPERLOK nuts finger-tight, where applicable.

# SPMBT

## Positionable Male Branch Tee

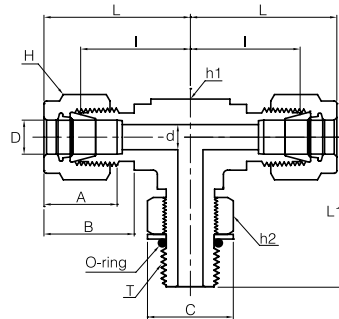

### Connects Fractional Tubes To Female ISO Parallel Thread

Part No.	Tube OD D (inch)	T (PF)	d Min	Width Across Flat			A	B	I	L	L1	C
				h1(inch)	h2(inch)	H(inch)						
SPMBT - 4 - 2G	1/4	1/8	4.06	1/2	9/16	9/16	15.24	17.78	19.56	26.92	26.42	17.27
SPMBT - 4 - 4G	1/4	1/4	4.83	5/8	3/4	9/16	15.24	17.78	21.59	28.96	32.26	22.86
SPMBT - 6 - 4G	3/8	1/4	5.08	5/8	3/4	11/16	15.24	19.30	23.11	30.48	32.26	22.86
SPMBT - 8 - 6G	3/8	3/8	7.87	13/16	7/8	7/8	22.86	21.84	25.91	36.07	37.08	26.42
SPMBT - 8 - 8G	1/2	1/2	10.41	15/16	1-1/16	7/8	22.86	21.84	27.94	38.10	43.43	32.00
SPMBT - 10 - 8G	5/8	1/2	11.94	15/16	1-1/16	1	24.38	21.84	27.94	38.10	43.43	32.00
SPMBT - 12 - 8G	3/4	1/2	11.94	1-1/16	1-1/16	1-1/8	24.38	21.84	29.72	39.88	45.21	32.00
SPMBT - 12 - 12G	3/4	3/4	15.75	1-1/16	1-3/8	1-1/8	24.38	21.84	29.72	39.88	48.77	41.15
SPMBT - 16 - 16G	1	1	19.81	1-3/8	1-5/8	1-1/2	31.24	26.42	36.83	49.02	53.59	48.51

### Connects Metric Tubes To Female ISO Parallel Thread

Part No.	Tube OD D	T (PF)	d Min	Width Across Flat			A	B	I	L	L1	C
				h1(inch)	h2(inch)	H						
SPMBT - 6M - 2G	6	1/8	4.0	1/2	9/16	14	15.3	17.7	19.6	27.0	26.4	17.3
SPMBT - 6M - 4G	6	1/4	4.8	5/8	3/4	14	15.3	17.7	21.6	29.0	32.3	22.9
SPMBT - 8M - 2G	8	1/8	4.0	9/16	9/16	16	16.2	18.6	21.3	28.8	27.4	17.3
SPMBT - 8M - 4G	8	1/4	5.9	5/8	3/4	16	16.2	18.6	22.4	29.9	32.2	22.9
SPMBT - 10M - 4G	10	1/4	5.9	13/16	3/4	19	17.2	19.5	25.9	33.5	35.0	22.9
SPMBT - 12M - 6G	10	3/8	7.9	13/16	7/8	22	22.8	22.0	25.9	36.0	37.1	26.4
SPMBT - 12M - 8G	12	1/4	9.5	15/16	1-1/16	22	22.8	22.0	27.9	38.0	43.4	32.0

### Connects Fractional Tubes To SAE/MS Straight Thread

Part No.	Tube OD D (inch)	T (U)	d Min	Width Across Flat			A	B	I	L	L1	C
				h1(inch)	h2(inch)	H(inch)						
SPMBT - 4 - 4U	1/4	7/16-20	4.83	1/2	9/16	9/16	15.24	17.78	21.08	28.45	28.45	16.51
SPMBT - 6 - 6U	3/8	9/16-18	7.11	5/8	11/16	11/16	16.76	19.30	24.64	32.00	32.26	20.07
SPMBT - 8 - 8U	1/2	3/4-16	10.41	13/16	7/8	7/8	22.86	21.84	27.43	37.59	37.85	25.65
SPMBT - 12 - 12U	3/4	1-1/16-12	15.75	1-1/16	1-1/4	1-1/8	24.38	21.84	31.24	41.40	48.77	36.58
SPMBT - 16 - 16U	1	1-5/16-12	22.35	1-3/8	1-1/2	1-1/2	31.24	26.42	38.35	50.55	53.59	43.94
SPMBT - 20 - 20U	1-1/4	1-5/8-12	27.69	1-11/16	1-7/8	1-7/8	41.15	38.86	45.72	67.82	58.17	54.86
SPMBT - 24 - 24U	1-1/2	1-7/8-12	34.04	2	2-1/8	2-1/4	50.04	45.21	50.80	77.98	60.45	62.23
SPMBT - 32 - 32U	2	2-1/2-12	45.97	2-3/4	2-3/4	3	67.56	62.74	69.85	107.19	71.63	80.26

- Dimensions and Drawings are for reference only and are subject to change without prior notice.  
 - Unless otherwise specified, all dimensions are in millimeters.  
 - Sizes, pressure classes, and end connections not listed are available upon request.  
 - Dimensions shown with SUPERLOK nuts finger-tight, where applicable.

# SMRT

## Male Run Tee

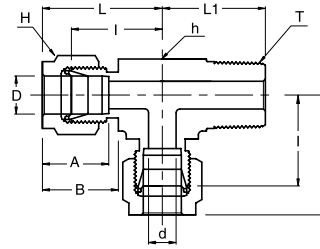

### Connects Fractional Tubes To Female NPT Thread

Part No.	Tube OD D (inch)	T* (NPT)	d Min	Width Across Flat		A	B	I	L	L1
				h (inch)	H (inch)					
SMRT - 2 - 2N	1/8	1/8	2.28	1/2	7/16	12.70	15.24	18.30	24.91	18.90
SMRT - 2 - 4N	1/8	1/4	2.28	1/2	7/16	12.70	15.24	18.03	24.63	23.36
SMRT - 3 - 2N	3/16	1/8	3.04	1/2	1/2	13.71	16.00	17.78	25.40	18.79
SMRT - 4 - 2N	1/4	1/8	4.82	1/2	9/16	15.24	17.78	19.55	26.92	18.79
SMRT - 4 - 4N	1/4	1/4	4.82	1/2	9/16	15.24	17.78	19.55	26.92	23.36
SMRT - 5 - 2N	5/16	1/8	4.82	5/8	5/8	16.25	18.54	22.35	29.71	20.82
SMRT - 6 - 4N	3/8	1/4	7.11	5/8	11/16	16.76	19.30	23.11	30.48	25.40
SMRT - 6 - 6N	3/8	3/8	7.11	5/8	11/16	16.76	19.30	23.10	30.48	28.19
SMRT - 8 - 6N	1/2	3/8	9.65	13/16	7/8	22.86	21.84	25.90	36.06	28.19
SMRT - 8 - 8N	1/2	1/2	10.41	13/16	7/8	22.86	21.84	25.90	36.06	33.02
SMRT - 10 - 8N	5/8	1/2	11.93	1	1	24.38	21.84	28.70	38.86	35.81
SMRT - 12 - 12N	3/4	3/4	15.74	1-1/16	1-1/8	24.38	21.84	29.71	39.87	36.83

### Connects Metric Tubes To Female ISO Tapered Thread

Part No.	Tube OD D	T* R (PT)	d Min	Width Across Flat		A	B	I	L	L1
				h	H					
SMRT - 3M - 2R	3	1/8	2.4	12.7	12	12.9	15.3	17.0	23.6	17.8
SMRT - 3M - 4R	3	1/4	2.4	12.7	12	12.9	15.3	18.0	24.6	23.4
SMRT - 4M - 2R	4	1/8	2.4	12.7	12	13.7	16.1	18.8	25.4	18.8
SMRT - 6M - 2R	6	1/8	4.8	12.7	14	15.3	17.7	19.6	27.0	18.8
SMRT - 6M - 4R	6	1/4	4.8	12.7	14	15.3	17.7	19.6	27.0	23.4
SMRT - 8M - 2R	8	1/8	4.8	15.9	16	16.2	18.6	22.4	29.9	20.8
SMRT - 8M - 4R	8	1/4	6.4	15.9	16	16.2	18.6	22.4	29.9	25.4
SMRT - 10M - 4R	10	1/4	7.1	17.5	19	17.2	19.5	23.9	31.5	28.2
SMRT - 10M - 6R	10	3/8	7.9	17.5	19	17.2	19.5	23.9	31.5	28.2
SMRT - 12M - 4R	12	1/4	7.1	20.6	22	22.8	22.0	25.9	36.0	28.2
SMRT - 12M - 6R	12	3/8	9.5	20.6	22	22.8	22.0	25.9	36.0	28.2
SMRT - 12M - 8R	12	1/2	9.5	20.6	22	22.8	22.0	25.9	36.0	33.0
SMRT - 16M - 6R	16	3/8	9.5	25.4	25	24.4	22.0	27.9	38.0	30.2
SMRT - 16M - 8R	16	1/2	11.9	25.4	25	24.4	22.0	27.9	38.0	35.1
SMRT - 20M - 12R	20	3/4	15.9	31.8	32	26.0	22.0	34.5	44.6	41.7

- Dimensions and Drawings are for reference only and are subject to change without prior notice.
- Unless otherwise specified, all dimensions are in millimeters.
- Sizes, pressure classes, and end connections not listed are available upon request.
- Dimensions shown with SUPERLOK nuts finger-tight, where applicable.

# SPMRT

## Positionable Male Run Tee

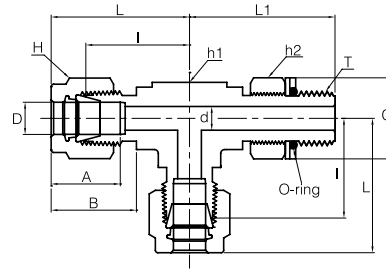

### Connects Fractional Tubes To Female ISO Parallel Thread

Part No.	Tube OD D (inch)	T (PF)	d Min	Width Across Flat			A	B	I	L	L1	C
				h1(inch)	h2(inch)	H(inch)						
SPMRT - 4 - 2G	1/4	1/8	4.06	1/2	9/16	9/16	15.24	17.78	19.56	26.92	26.42	17.27
SPMRT - 4 - 4G	1/4	1/4	4.83	5/8	3/4	9/16	15.24	17.78	21.59	28.96	32.26	22.86
SPMRT - 6 - 4G	3/8	1/4	5.84	5/8	3/4	11/16	16.76	19.30	23.11	30.48	32.26	22.86
SPMRT - 8 - 6G	1/4	3/8	7.87	13/16	7/8	7/8	22.86	21.84	25.91	36.07	37.08	26.42
SPMRT - 8 - 8G	3/8	1/2	10.41	15/16	1-1/16	7/8	22.86	21.84	27.94	38.10	43.43	32.00
SPMRT - 10 - 8G	1/2	1/2	11.94	15/16	1-1/16	1	24.38	21.84	27.94	38.10	43.43	32.00
SPMRT - 12 - 8G	3/4	1/2	11.94	1-1/16	1-1/16	1-1/8	24.38	21.84	29.72	39.88	45.21	32.00
SPMRT - 12 - 12G	3/4	3/4	15.75	1-1/16	1-3/8	1-1/8	24.38	21.84	29.72	39.88	48.77	41.15
SPMRT - 16 - 16G	1	1	19.81	1-3/8	1-5/8	1-1/2	31.24	26.42	36.83	49.02	53.59	48.51

### Connects Metric Tubes To Female ISO Parallel Thread

Part No.	Tube OD D	T (PF)	d Min	Width Across Flat			A	B	I	L	L1	C
				h1(inch)	h2(inch)	H						
SPMRT - 6M - 2G	6	1/8	4.0	1/2	9/16	14	15.3	17.7	19.6	27.0	26.4	17.3
SPMRT - 6M - 4G	6	1/4	4.8	5/8	3/4	14	15.3	17.7	21.6	29.0	32.2	22.9
SPMRT - 8M - 2G	8	1/8	4.0	9/16	9/16	16	16.2	18.6	21.3	28.8	27.4	17.3
SPMRT - 8M - 4G	8	1/4	6.4	5/8	3/4	16	16.2	18.6	22.4	29.9	32.2	22.9
SPMRT - 10M - 4G	10	1/4	5.9	13/16	3/4	19	17.2	19.5	25.9	33.5	35.0	22.9
SPMRT - 12M - 6G	10	3/8	7.9	13/16	7/8	22	22.8	22.0	25.9	36.0	37.1	26.4
SPMRT - 12M - 8G	12	1/2	9.5	15/16	1-1/16	22	22.8	22.0	27.9	38.0	43.4	22.9

### Connects Fractional Tubes To SAE/MS Straight Thread

Part No.	Tube OD D (inch)	T (U)	d Min	Width Across Flat			A	B	I	L	L1	C
				h1(inch)	h2(inch)	H(inch)						
SPMRT - 4 - 4U	1/4	7/16-20	4.83	1/2	9/16	9/16	15.24	17.78	21.08	28.45	28.45	16.51
SPMRT - 6 - 6U	3/8	9/16-18	7.11	5/8	11/16	11/16	16.76	19.30	24.64	32.00	32.26	20.07
SPMRT - 8 - 8U	1/2	3/4-16	10.41	13/16	7/8	7/8	22.86	21.84	27.43	37.59	37.85	25.65
SPMRT - 12 - 12U	3/4	1-1/16-12	15.75	1-1/16	1-1/4	1-1/8	24.38	21.84	31.24	41.40	48.77	36.58
SPMRT - 16 - 16U	1	1-5/16-12	22.35	1-3/8	1-1/2	1-1/2	31.24	26.42	38.35	50.55	53.59	43.94
SPMRT - 20 - 20U	1-1/4	1-5/8-12	27.69	1-11/16	1-7/8	1-7/8	41.15	38.86	45.72	67.82	58.17	54.86
SPMRT - 24 - 24U	1-1/2	1-7/8-12	34.04	2	2-1/8	2-1/4	50.04	45.21	50.80	77.98	60.45	62.23
SPMRT - 32 - 32U	2	2-1/2-12	45.97	2-3/4	2-3/4	3	67.56	62.74	69.85	107.19	71.63	80.26

- Dimensions and Drawings are for reference only and are subject to change without prior notice.  
 - Unless otherwise specified, all dimensions are in millimeters.  
 - Sizes, pressure classes, and end connections not listed are available upon request.  
 - Dimensions shown with SUPERLOK nuts finger-tight, where applicable.

# SFBT

## Female Branch Tee

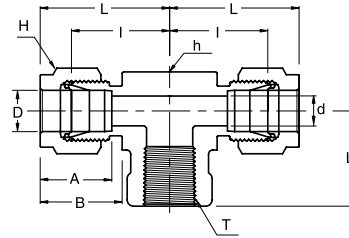

### Connects Fractional Tubes To Male NPT Thread

Part No.	Tube OD D (inch)	T * (NPT)	d Min	Width Across Flat		A	B	I	L	L1
				h (inch)	H (inch)					
SFBT - 2 - 2N	1/8	1/8	2.28	1/2	7/16	12.70	15.24	18.03	24.63	19.05
SFBT - 4 - 2N	1/4	1/8	4.82	1/2	9/16	15.24	17.78	19.55	26.92	19.05
SFBT - 4 - 4N	1/4	1/4	4.82	11/16	9/16	15.24	17.78	22.35	29.71	22.35
SFBT - 6 - 4N	3/8	1/4	7.11	11/16	11/16	16.76	19.30	23.87	31.24	22.35
SFBT - 6 - 6N	3/8	3/8	7.11	13/16	11/16	16.76	19.30	25.90	33.27	22.35
SFBT - 6 - 8N	3/8	1/2	7.11	1	11/16	16.76	19.30	28.70	36.07	28.45
SFBT - 8 - 4N	1/2	1/4	10.41	13/16	7/8	22.86	21.84	25.90	36.06	22.35
SFBT - 8 - 6N	1/2	3/8	10.41	13/16	7/8	22.86	21.84	25.90	36.06	22.35
SFBT - 8 - 8N	1/2	1/2	10.41	1	7/8	22.86	21.84	28.70	38.86	28.44
SFBT - 10 - 8N	5/8	1/2	12.70	1	1	24.38	21.84	28.70	38.86	28.44
SFBT - 12 - 12N	3/4	3/4	15.74	1-3/8	1-1/8	24.38	21.84	34.54	44.70	31.75
SFBT - 16 - 12N	1	3/4	22.35	1-3/8	1-1/2	31.24	26.41	36.83	49.02	31.75
SFBT - 16 - 16N	1	1	22.35	1-11/16	1-1/2	31.24	26.41	41.40	53.59	38.10

### Connects Metric Tubes To Male NPT Thread

Part No.	Tube OD D	T * (NPT)	d Min	Width Across Flat		A	B	I	L	L1
				h	H					
SFBT - 6M - 2N	6	1/8	4.8	12.70	14	15.3	17.7	19.6	27.0	19.0
SFBT - 6M - 4N	6	1/4	4.8	17.46	14	15.3	17.7	22.4	29.8	22.4
SFBT - 6M - 6N	6	3/8	4.8	20.63	14	15.3	17.7	24.4	31.7	22.4
SFBT - 6M - 8N	6	1/2	4.8	25.40	14	15.3	17.7	27.2	34.5	28.4
SFBT - 8M - 2N	8	1/8	6.4	15.87	16	16.2	18.6	22.4	29.9	19.0
SFBT - 8M - 4N	8	1/4	6.4	17.46	16	16.2	18.6	23.1	30.6	22.4
SFBT - 8M - 6N	8	3/8	6.4	20.63	16	16.2	18.6	25.2	32.4	22.4
SFBT - 8M - 8N	8	1/2	6.4	25.40	16	16.2	18.6	28.0	35.2	28.4
SFBT - 10M - 4N	10	1/4	7.9	20.63	19	17.2	19.5	25.9	33.5	22.4
SFBT - 10M - 6N	10	3/8	7.9	20.63	19	17.2	19.5	25.9	33.3	22.4
SFBT - 10M - 8N	10	1/2	9.5	25.40	19	17.2	19.5	26.2	33.6	22.4
SFBT - 12M - 4N	12	1/4	9.5	20.63	22	22.8	22.0	25.9	36.0	22.4
SFBT - 12M - 6N	12	3/8	9.5	20.63	22	22.8	22.0	25.9	36.0	22.4
SFBT - 12M - 8N	12	1/2	9.5	25.40	22	22.8	22.0	29.7	40.0	28.4
SFBT - 16M - 8N	16	1/2	12.7	25.40	25	24.4	22.0	28.7	38.8	28.4

- Dimensions and Drawings are for reference only and are subject to change without prior notice.  
 - Unless otherwise specified, all dimensions are in millimeters.  
 - Sizes, pressure classes, and end connections not listed are available upon request.  
 - Dimensions shown with SUPERLOK nuts finger-tight, where applicable.

# SFRT

## Female Run Tee

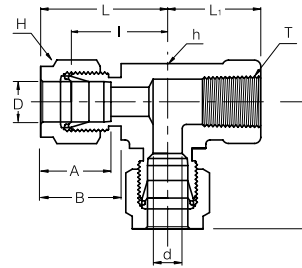

### Connects Fractional Tubes To Male NPT Thread

Part No.	Tube OD D (inch)	T* (NPT)	d Min	Width Across Flat		A	B	I	L	L1
				h (inch)	H (inch)					
SFRT - 2 - 2N	1/8	1/8	2.28	1/2	7/16	12.70	15.24	18.03	24.63	19.05
SFRT - 4 - 2N	1/4	1/8	4.82	1/2	9/16	15.24	17.78	19.55	26.92	19.05
SFRT - 4 - 4N	1/4	1/4	4.82	11/16	9/16	15.24	17.78	22.35	29.71	22.35
SFRT - 6 - 4N	3/8	1/4	7.11	11/16	11/16	16.76	19.30	23.87	31.24	22.35
SFRT - 8 - 6N	1/2	3/8	10.41	13/16	7/8	22.86	21.84	25.90	36.06	22.35
SFRT - 8 - 8N	1/2	1/2	10.41	1	7/8	22.86	21.84	28.70	39.87	28.44
SFRT - 12 - 12N	3/4	3/4	15.74	1-3/8	1-1/8	24.38	21.84	34.54	44.70	31.75
SFRT - 16 - 12N	1	3/4	22.35	1-3/8	1-1/2	31.24	26.41	36.83	49.02	31.75
SFRT - 16 - 16N	1	1	22.35	1-11/16	1-1/2	31.24	26.41	41.40	53.59	38.10

### Connects Metric Tubes To Male NPT Thread

Part No.	Tube OD D	T* (NPT)	d Min	Width Across Flat		A	B	I	L	L1
				h	H					
SFRT - 6M - 2N	6	1/8	4.8	12.70	14	15.3	17.7	19.6	27.0	19.0
SFRT - 6M - 4N	6	1/4	4.8	17.46	14	15.3	17.7	22.4	29.8	22.4
SFRT - 6M - 8N	6	1/2	4.8	25.40	14	15.3	17.7	27.2	34.5	28.4
SFRT - 8M - 2N	8	1/8	6.4	15.87	16	16.2	18.6	22.4	29.9	19.0
SFRT - 8M - 4N	8	1/4	6.4	17.46	16	16.2	18.6	23.1	30.6	22.4
SFRT - 8M - 6N	8	3/8	6.4	20.63	16	16.2	18.6	25.2	32.4	22.4
SFRT - 8M - 8N	8	1/2	6.4	25.40	16	16.2	18.6	28.0	35.2	28.4
SFRT - 12M - 4N	12	1/4	9.5	20.63	22	22.8	22.0	25.9	33.5	22.4
SFRT - 12M - 6N	12	3/8	9.5	20.63	22	22.8	22.0	25.9	36.0	22.4
SFRT - 12M - 8N	12	1/2	9.5	25.40	22	22.8	22.0	29.7	40.0	28.4
SFRT - 16M - 8N	16	1/2	12.7	25.40	25	24.4	22.0	29.7	39.8	28.4

- Dimensions and Drawings are for reference only and are subject to change without prior notice.
- Unless otherwise specified, all dimensions are in millimeters.
- Sizes, pressure classes, and end connections not listed are available upon request.
- Dimensions shown with SUPERLOK nuts finger-tight, where applicable.



# SUC

## Union Cross

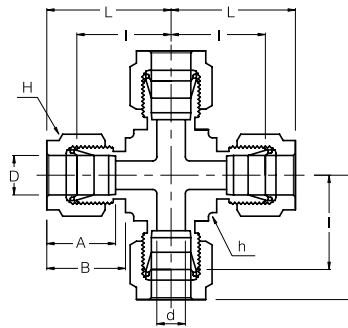

### Connects Fractional Tubes

Part No.	Tube OD D (inch)	d Min	Width Across Flat		A	B	I	L
			h (inch)	H (inch)				
SUC - 1	1/16	1.27	3/8	5/16	8.63	10.92	14.00	18.03
SUC - 2	1/8	2.28	3/8	7/16	12.70	15.24	15.74	22.35
SUC - 3	3/16	3.04	1/2	1/2	13.71	16.00	18.54	25.14
SUC - 4	1/4	4.82	1/2	9/16	15.24	17.78	19.55	26.92
SUC - 5	5/16	6.35	5/8	5/8	16.25	18.54	22.35	29.71
SUC - 6	3/8	7.11	5/8	11/16	16.76	19.30	23.11	30.48
SUC - 8	1/2	10.41	13/16	7/8	22.86	21.84	25.90	36.06
SUC - 10	5/8	12.70	15/16	1	24.38	21.84	28.70	38.80
SUC - 12	3/4	15.74	1	1-1/8	24.38	21.84	29.71	39.87
SUC - 14	7/8	18.28	1-3/8	1-1/4	25.90	21.84	34.54	44.70
SUC - 16	1	22.35	1-3/8	1-1/2	31.24	26.41	36.83	49.02

### Connects Metric Tubes

Part No.	Tube OD D	d Min	Width Across Flat		A	B	I	L
			h	H				
SUC - 3M	3	2.4	9.5	12	12.9	15.3	15.7	22.3
SUC - 6M	6	4.8	12.7	14	15.3	17.7	19.6	27.0
SUC - 8M	8	6.4	15.9	16	16.2	18.6	22.4	29.9
SUC - 10M	10	7.9	20.6	19	17.2	19.5	25.9	33.5
SUC - 12M	12	9.5	20.6	22	22.8	22.0	25.9	36.0
SUC - 16M	16	12.7	23.8	25	24.4	22.0	26.9	37.0
SUC - 18M	18	15.1	25.4	30	24.4	22.0	28.2	38.3
SUC - 20M	20	15.9	34.9	32	26.0	22.0	34.5	44.6
SUC - 25M	25	21.8	34.9	38	31.3	26.5	36.8	49.1

- Dimensions and Drawings are for reference only and are subject to change without prior notice.  
 - Unless otherwise specified, all dimensions are in millimeters.  
 - Sizes, pressure classes, and end connections not listed are available upon request.  
 - Dimensions shown with SUPERLOK nuts finger-tight, where applicable.

**SR**  
Reducer

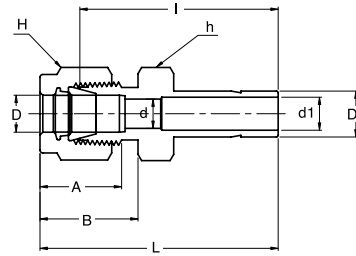

**Connects Fractional Tubes To Fractional SUPERLOK® Port**

Part No.	Tube OD		d Min	d1 Min	Width Across Flat		A	B	I	L
	D (inch)	D1 (inch)			h (inch)	H (inch)				
SR - 2 - 1	1/8	1/16	2.28	0.8	7/16	7/16	12.70	15.24	22.35	28.95
SR - 2 - 2	1/8	1/8	2.28	2.1	7/16	7/16	12.70	15.24	26.92	33.52
SR - 2 - 3	1/8	3/16	2.28	3.0	7/16	7/16	12.70	15.24	27.68	34.29
SR - 2 - 4	1/8	1/4	2.28	4.4	7/16	7/16	12.70	15.24	29.46	36.06
SR - 2 - 6	1/8	3/8	2.28	6.9	7/16	7/16	12.70	15.24	30.98	37.59
SR - 2 - 8	1/8	1/2	2.28	9.4	9/16	7/16	12.70	15.24	37.59	44.19
SR - 3 - 2	3/16	1/8	3.04	2.03	7/16	1/2	13.71	16.00	28.19	34.79
SR - 3 - 4	3/16	1/4	3.04	4.4	7/16	1/2	13.71	16.00	30.48	37.08
SR - 4 - 2	1/4	1/8	4.83	2.1	1/2	9/16	15.24	17.78	29.46	36.83
SR - 4 - 3	1/4	3/16	4.83	3.0	1/2	9/16	15.24	17.78	30.22	37.59
SR - 4 - 4	1/4	1/4	4.83	4.4	1/2	9/16	15.24	17.78	31.75	39.11
SR - 4 - 5	1/4	5/16	4.83	5.6	1/2	9/16	15.24	17.78	32.51	39.87
SR - 4 - 6	1/4	3/8	4.83	6.9	1/2	9/16	15.24	17.78	33.27	40.64
SR - 4 - 8	1/4	1/2	4.83	9.4	9/16	9/16	15.24	17.78	38.86	46.22
SR - 4 - 10	1/4	5/8	4.83	12.0	11/16	9/16	15.24	17.78	40.64	48.00
SR - 4 - 12	1/4	3/4	4.83	14.8	13/16	9/16	15.24	17.78	41.40	47.75
SR - 5 - 6	5/16	3/8	6.35	6.9	9/16	5/8	16.25	18.54	34.54	41.91
SR - 5 - 8	5/16	1/2	6.35	9.4	9/16	5/8	16.25	18.54	40.13	47.49
SR - 6 - 4	3/8	1/4	7.11	4.4	5/8	11/16	16.76	19.30	34.03	41.40
SR - 6 - 6	3/8	3/8	7.11	6.9	5/8	11/16	16.76	19.30	35.81	43.18
SR - 6 - 8	3/8	1/2	7.11	9.4	5/8	11/16	16.76	19.30	41.14	48.51
SR - 6 - 10	3/8	5/8	7.11	12.0	11/16	11/16	16.76	19.30	42.92	50.29
SR - 6 - 12	3/8	3/4	7.11	14.8	13/16	11/16	16.76	19.30	42.92	50.29
SR - 8 - 4	1/2	1/4	10.41	4.4	13/16	7/8	22.86	21.84	34.79	44.95
SR - 8 - 6	1/2	3/8	10.41	6.9	13/16	7/8	22.86	21.84	36.57	46.73
SR - 8 - 8	1/2	1/2	10.41	9.4	13/16	7/8	22.86	21.84	42.16	52.32
SR - 8 - 10	1/2	5/8	10.41	12.0	13/16	7/8	22.86	21.84	43.68	53.84
SR - 8 - 12	1/2	3/4	10.41	14.8	13/16	7/8	22.86	21.84	43.68	53.84
SR - 8 - 16	1/2	1	10.41	20.4	1-1/16	7/8	22.86	21.84	50.03	60.19
SR - 10 - 12	5/8	3/4	12.70	14.8	15/16	1	24.38	21.84	44.45	54.61
SR - 10 - 14	5/8	7/8	12.70	17.0	15/16	1	24.38	21.84	45.97	56.13
SR - 10 - 16	5/8	1	12.70	20.4	1-1/16	1	24.38	21.84	50.80	60.96
SR - 12 - 8	3/4	1/2	15.74	9.4	1-1/16	1-1/8	24.38	21.84	44.45	54.61
SR - 12 - 16	3/4	1	15.74	20.4	1-1/16	1-1/8	24.38	21.84	52.32	62.48

- Dimensions and Drawings are for reference only and are subject to change without prior notice.  
 - Unless otherwise specified, all dimensions are in millimeters.  
 - Sizes, pressure classes, and end connections not listed are available upon request.  
 - Dimensions shown with SUPERLOK nuts finger-tight, where applicable.

# SR

## Reducer

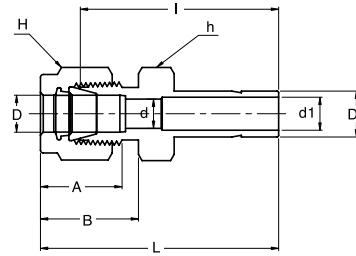

### Connects Metric Tubes To Metric SUPERLOK® Port

Part No.	Tube OD		d Min	d1 Min	Width Across Flat		A	B	I	L
	D	D1			h	H				
SR - 3M - 4M	3	4	2.4	2.2	12	12	12.9	15.3	28.4	35.0
SR - 3M - 6M	3	6	2.4	4.1	12	12	12.9	15.3	29.5	36.1
SR - 3M - 10M	3	10	2.4	7.1	14	12	12.9	15.3	31.8	38.4
SR - 4M - 6M	4	6	2.4	4.1	12	12	13.7	16.1	30.5	37.1
SR - 6M - 3M	6	3	4.8	1.8	14	14	15.3	17.7	29.5	36.9
SR - 6M - 8M	6	8	4.8	5.6	14	14	15.3	17.7	32.5	39.9
SR - 6M - 10M	6	10	4.8	7.1	14	14	15.3	17.7	33.3	40.7
SR - 6M - 12M	6	12	4.8	8.8	14	14	15.3	17.7	38.9	46.3
SR - 8M - 6M	8	6	6.4	4.1	15	16	16.2	18.6	32.8	40.3
SR - 8M - 10M	8	10	6.4	7.1	15	16	16.2	18.6	34.5	42.0
SR - 8M - 12M	8	12	6.4	8.8	15	16	16.2	18.6	40.1	47.6
SR - 10M - 6M	10	6	7.9	4.1	18	19	17.2	19.5	34.8	42.4
SR - 10M - 8M	10	8	7.9	5.6	18	19	17.2	19.5	35.8	43.4
SR - 10M - 12M	10	12	7.9	8.8	18	19	17.2	19.5	42.2	49.8
SR - 10M - 15M	10	15	7.9	11.2	18	19	17.2	19.5	43.7	51.3
SR - 10M - 18M	10	18	7.9	13.9	22	19	17.2	19.5	43.7	51.3
SR - 12M - 6M	12	6	9.5	4.1	22	22	22.8	22.0	34.8	44.9
SR - 12M - 8M	12	8	9.5	5.6	22	22	22.8	22.0	35.8	45.9
SR - 12M - 10M	12	10	9.5	7.1	22	22	22.8	22.0	36.6	46.7
SR - 12M - 16M	12	16	9.5	12.0	22	22	22.8	22.0	43.7	53.8
SR - 12M - 18M	12	18	9.5	13.9	22	22	22.8	22.0	43.7	53.8
SR - 12M - 20M	12	20	9.5	15.5	22	22	22.8	22.0	46.0	56.1
SR - 12M - 22M	12	22	9.5	17.9	24	22	22.8	22.0	46.0	56.1
SR - 12M - 25M	12	25	9.5	19.9	27	22	22.8	22.0	52.3	62.4
SR - 16M - 12M	16	12	12.7	8.8	27	25	24.4	22.0	42.9	53.0
SR - 18M - 12M	18	12	15.1	8.8	27	30	24.4	22.0	44.5	54.6
SR - 18M - 16M	18	16	15.1	12.0	27	30	24.4	22.0	46.0	56.1
SR - 18M - 20M	18	20	15.1	15.5	27	30	24.4	22.0	47.5	57.6
SR - 18M - 22M	18	22	15.1	17.9	30	30	24.4	22.0	47.5	57.6
SR - 18M - 25M	18	25	15.1	19.9	30	30	24.4	22.0	52.3	62.4
SR - 20M - 16M	20	16	15.9	12.0	30	32	26.0	22.0	47.8	57.9
SR - 20M - 18M	20	18	15.9	13.9	30	32	26.0	22.0	47.8	57.9
SR - 20M - 22M	20	22	15.9	17.9	30	32	26.0	22.0	49.3	59.4
SR - 20M - 25M	20	25	15.9	19.9	30	32	26.0	22.0	54.1	64.2
SR - 22M - 18M	22	18	18.3	13.9	30	32	26.0	22.0	47.8	57.9
SR - 22M - 20M	22	20	18.3	15.5	30	32	26.0	22.0	49.3	59.4
SR - 22M - 25M	22	25	18.3	19.9	30	32	26.0	22.0	54.1	64.2
SR - 25M - 18M	25	18	21.8	13.9	35	38	31.3	26.5	50.8	63.1
SR - 25M - 20M	25	20	21.8	15.5	35	38	31.3	26.5	52.3	64.6

- Dimensions and Drawings are for reference only and are subject to change without prior notice.

- Unless otherwise specified, all dimensions are in millimeters.

- Sizes, pressure classes, and end connections not listed are available upon request.

- Dimensions shown with SUPERLOK nuts finger-tight, where applicable.

**SR**  
Reducer

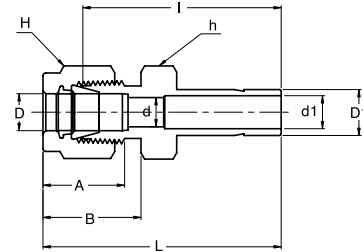

Connects Metric Tubes To Fractional SUPERLOK® Port

Part No.	Tube OD		d Min	d1 Min	Width Across Flat		A	B	I	L
	D	D1 (inch)			h	H				
SR - 3M - 2	3	1/8	2.4	2.1	12	12	12.9	15.3	26.9	33.5
SR - 3M - 4	3	1/4	2.4	4.4	12	12	12.9	15.3	29.5	36.1
SR - 6M - 4	6	1/4	4.8	4.4	14	14	15.3	17.7	31.8	39.2
SR - 6M - 5	6	5/16	4.8	5.6	14	14	15.3	17.7	32.5	39.9
SR - 6M - 6	6	3/8	4.8	6.9	14	14	15.3	17.7	33.3	40.7
SR - 6M - 8	6	1/2	4.8	9.4	14	14	15.3	17.7	38.9	46.3
SR - 8M - 6	8	3/8	6.4	6.9	15	16	16.2	18.6	34.5	42.0
SR - 8M - 8	8	1/2	6.4	9.4	15	16	16.2	18.6	40.1	47.6
SR - 10M - 6	10	3/8	7.9	6.9	18	19	17.2	19.5	36.6	44.2
SR - 10M - 8	10	1/2	7.9	9.4	18	19	17.2	19.5	42.2	49.8
SR - 12M - 8	12	1/2	9.5	9.4	22	22	22.8	22.0	42.2	52.3
SR - 12M - 12	12	3/4	9.5	14.8	22	22	22.8	22.0	43.7	53.8
SR - 18M - 12	18	3/4	15.1	14.8	27	30	24.4	22.0	46.0	56.1
SR - 18M - 16	18	1	15.1	20.4	27	30	24.4	22.0	52.3	62.4

**SRB**  
Bulkhead Reducer

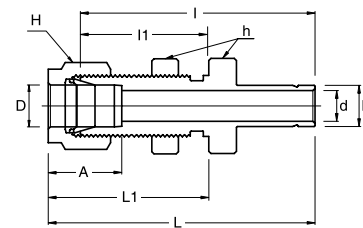

Connects Fractional Tubes To Fractional SUPERLOK® Port

Part No.	Tube O.D. D (inch)	d Min	Width Across Flat		A	I	I1	L	L1	Panel Hole Drill Size	Panel Max. Thickness
			h (inch)	H (inch)							
SRB - 2 - 2	1/8	2.1	1/2	7/16	12.70	42.92	24.63	49.53	31.24	8.33	12.70
SRB - 4 - 4	1/4	4.4	5/8	9/16	15.24	48.51	26.16	55.88	33.52	11.50	10.16
SRB - 6 - 6	3/8	6.9	3/4	11/16	16.76	53.84	29.46	61.21	36.83	14.68	11.17
SRB - 8 - 8	1/2	9.4	15/16	7/8	22.86	62.73	31.75	72.89	41.91	19.44	12.70
SRB - 10 - 10	5/8	12.0	1-1/16	1	24.38	65.02	32.51	75.18	42.67	22.62	12.70
SRB - 16 - 16	1	20.4	1-5/8	1-1/2	31.24	88.13	45.21	100.33	57.40	33.73	19.05

- Dimensions and Drawings are for reference only and are subject to change without prior notice.  
 - Unless otherwise specified, all dimensions are in millimeters.  
 - Sizes, pressure classes, and end connections not listed are available upon request.  
 - Dimensions shown with SUPERLOK nuts finger-tight, where applicable.

## SMA

### Male Adapter

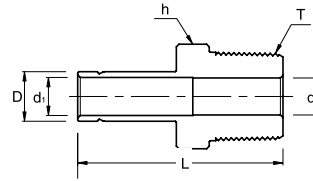

#### Connects Fractional SUPERLOK® Port To Female NPT Thread

Part No.	Tube OD D (inch)	T* (NPT)	d (Min)	d1	Width Across Flat h (inch)	L
SMA - 2 - 2N	1/8	1/8	4.82	2.10	7/16	29.50
SMA - 2 - 4N	1/8	1/4	7.11	2.10	9/16	34.80
SMA - 3 - 2N	3/16	1/8	4.82	3.04	7/16	30.22
SMA - 3 - 4N	3/16	1/4	7.11	3.04	9/16	35.56
SMA - 4 - 2N	1/4	1/8	4.40	4.40	7/16	31.80
SMA - 4 - 4N	1/4	1/4	4.40	4.40	9/16	37.08
SMA - 4 - 6N	1/4	3/8	4.40	4.40	11/16	37.84
SMA - 4 - 8N	1/4	1/2	4.40	4.40	7/8	43.43
SMA - 5 - 2N	5/16	1/8	4.82	5.60	7/16	32.76
SMA - 5 - 4N	5/16	1/4	6.35	5.60	9/16	38.10
SMA - 6 - 2N	3/8	1/8	4.82	6.90	7/16	33.50
SMA - 6 - 4N	3/8	1/4	6.90	6.90	9/16	38.90
SMA - 6 - 6N	3/8	3/8	6.90	6.90	11/16	39.60
SMA - 6 - 8N	3/8	1/2	6.90	6.90	7/8	45.20
SMA - 8 - 4N	1/2	1/4	7.11	9.40	9/16	44.50
SMA - 8 - 6N	1/2	3/8	9.40	9.40	11/16	45.20
SMA - 8 - 8N	1/2	1/2	9.40	9.40	7/8	50.80
SMA - 10 - 6N	5/8	3/8	9.90	12.00	11/16	47.40
SMA - 10 - 8N	5/8	1/2	12.00	12.00	7/8	52.30
SMA - 10 - 12N	5/8	3/4	14.98	12.00	1-1/16	52.30
SMA - 12 - 8N	3/4	1/2	11.94	14.80	7/8	52.30
SMA - 12 - 12N	3/4	3/4	14.80	14.80	1-1/16	52.30
SMA - 12 - 16N	3/4	1	20.32	14.80	1-3/8	57.91
SMA - 14 - 12N	7/8	3/4	14.98	17.27	1-1/16	54.30
SMA - 16 - 12N	1	3/4	15.74	20.40	1-1/16	58.70
SMA - 16 - 16N	1	1	20.40	20.40	1-3/8	66.00

#### Connects Metric SUPERLOK® Port To Female NPT Thread

Part No.	Tube OD D (inch)	T* (NPT)	d (Min)	d1	Width Across Flat h (inch)	L
SMA - 6M - 2N	6	1/8	4.1	4.1	12	32.8
SMA - 6M - 4N	6	1/4	4.1	4.1	14	38.1
SMA - 8M - 4N	8	1/4	5.6	5.6	14	39.1
SMA - 10M - 4N	10	1/4	7.1	7.1	14	39.9
SMA - 10M - 6N	10	3/8	7.1	7.1	18	40.6
SMA - 10M - 8N	10	1/2	11.9	7.1	22	46.2
SMA - 12M - 4N	12	1/4	7.1	8.8	16	46.5
SMA - 12M - 8N	12	1/2	11.9	8.8	22	52.0
SMA - 18M - 12N	18	3/4	15.9	13.9	27	54.8

- Dimensions and Drawings are for reference only and are subject to change without prior notice.
- Unless otherwise specified, all dimensions are in millimeters.
- Sizes, pressure classes, and end connections not listed are available upon request.
- Dimensions shown with SUPERLOK nuts finger-tight, where applicable.

# SFA

## Female Adapter

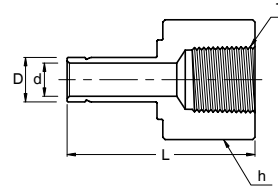

### Connects Fractional SUPERLOK® Port To Male NPT Thread

Part No.	Tube OD D (inch)	T* (NPT)	d (Min)	Width Across Flat h (inch)	L
SFA - 2 - 2N	1/8	1/8	2.10	9/16	31.50
SFA - 2 - 4N	1/8	1/4	2.10	3/4	35.30
SFA - 3 - 2N	3/16	1/8	3.04	9/16	32.00
SFA - 3 - 4N	3/16	1/4	3.04	3/4	35.81
SFA - 4 - 2N	1/4	1/8	4.40	9/16	33.02
SFA - 4 - 4N	1/4	1/4	4.40	3/4	37.10
SFA - 4 - 6N	1/4	3/8	4.40	7/8	39.37
SFA - 4 - 8N	1/4	1/2	4.40	1-1/16	45.50
SFA - 5 - 2N	5/16	1/8	5.60	9/16	34.29
SFA - 5 - 4N	5/16	1/4	5.60	3/4	37.59
SFA - 6 - 2N	3/8	1/8	6.90	9/16	34.29
SFA - 6 - 4N	3/8	1/4	6.90	3/4	38.10
SFA - 6 - 6N	3/8	3/8	6.90	7/8	40.38
SFA - 6 - 8N	3/8	1/2	6.90	1-1/16	46.73
SFA - 8 - 4N	1/2	1/4	9.40	3/4	43.43
SFA - 8 - 6N	1/2	3/8	9.40	7/8	45.46
SFA - 8 - 8N	1/2	1/2	9.40	1-1/16	51.80
SFA - 10 - 6N	5/8	3/8	12.00	7/8	48.26
SFA - 10 - 8N	5/8	1/2	12.00	1-1/16	53.08
SFA - 12 - 8N	3/4	1/2	14.80	1-1/16	52.83
SFA - 12 - 12N	3/4	3/4	14.80	1-5/16	54.86
SFA - 12 - 16N	3/4	1	14.80	1-5/8	58.42
SFA - 14 - 12N	7/8	3/4	17.27	1-5/16	57.15
SFA - 16 - 12N	1	3/4	20.40	1-5/16	60.70
SFA - 16 - 16N	1	1	20.40	1-5/8	64.26

### Connects Metric SUPERLOK® Port To Male NPT Thread

Part No.	Tube OD D (inch)	T* (NPT)	d (Min)	Width Across Flat h (inch)	L
SFA - 3M - 2N	3	1/8	1.8	14	31.2
SFA - 6M - 2N	6	1/8	4.1	14	32.5
SFA - 6M - 4N	6	1/4	4.1	19	37.1
SFA - 8M - 4N	8	1/4	5.6	19	37.6
SFA - 10M - 4N	10	1/4	7.1	19	38.1
SFA - 10M - 6N	10	3/8	7.1	22	40.1
SFA - 10M - 8N	10	1/2	7.1	27	46.5
SFA - 12M - 4N	12	1/4	8.8	19	43.7
SFA - 12M - 6N	12	3/8	8.8	22	46.0
SFA - 12M - 8N	12	1/2	8.8	27	52.3
SFA - 18M - 12N	18	3/4	13.9	32	54.8

- Dimensions and Drawings are for reference only and are subject to change without prior notice.
- Unless otherwise specified, all dimensions are in millimeters.
- Sizes, pressure classes, and end connections not listed are available upon request.
- Dimensions shown with SUPERLOK nuts finger-tight, where applicable.

## To Solve Adapter Alignment Problems

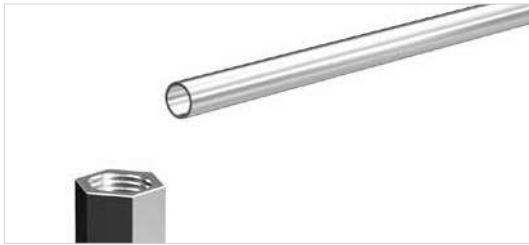

1. Required installation is to connect tubing in direction shown, to a female port.



3. To connect this situation, merely tighten pipe thread of male adapter into female port.



2. With pipe connection tight, the male elbow is pointing in the wrong direction for desired tubing run.



4. Connect union elbow to adapter by tightening SUPERLOK connection with wrench while holding elbow pointing in desired direction. Then insert tubing into the other end of the Union Elbow and connect tubing.

## SPC

### Port Connector

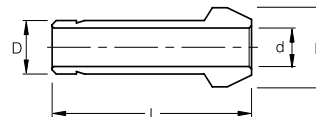

#### Connects Fractional SUPERLOK® Ports

Part No.	Tube OD D (inch)	d (Min)	E	L
SPC - 2	1/8	2.1	6.09	22.35
SPC - 4	1/4	4.4	9.39	25.30
SPC - 5	5/16	5.6	10.92	25.90
SPC - 6	3/8	6.9	12.70	26.70
SPC - 8	1/2	9.4	15.74	35.81
SPC - 12	3/4	14.8	22.09	38.10
SPC - 16	1	20.4	28.44	48.00

#### Connects Metric SUPERLOK® Ports

Part No.	Tube OD D (inch)	d (Min)	E	L
SPC - 3M	3	1.9	6.0	22.2
SPC - 6M	6	4.1	9.0	24.6
SPC - 8M	8	5.6	11.0	28.5
SPC - 10M	10	7.1	13.1	26.1
SPC - 12M	12	8.8	15.0	35.8
SPC - 16M	16	12.0	19.0	37.4

- Dimensions and Drawings are for reference only and are subject to change without prior notice.
- Unless otherwise specified, all dimensions are in millimeters.
- Sizes, pressure classes, and end connections not listed are available upon request.
- Dimensions shown with SUPERLOK nuts finger-tight, where applicable.

# SRPC

## Reducing Port Connector



### Connects Fractional SUPERLOK® Port To Male AN

Part No.	Tube O.D. D1 (inch)	Reduced Tube O.D. D (inch)	d	E	l	l1	L
SRPC - 2 - 1	1/8	1/16	0.76	6.09	8.63	2.03	17.27
SRPC - 4 - 1	1/4	1/16	0.76	9.39	8.63	3.55	18.03
SRPC - 4 - 2	1/4	1/8	2.10	9.39	13.46	3.30	22.60
SRPC - 6 - 2	3/8	1/8	2.10	12.70	13.46	3.81	23.11
SRPC - 6 - 4	3/8	1/4	4.40	12.70	15.74	3.30	24.89
SRPC - 8 - 4	1/2	1/4	4.40	15.74	15.74	3.81	29.21
SRPC - 8 - 6	1/2	3/8	6.90	15.74	17.52	3.30	30.48
SRPC - 12 - 8	3/4	1/2	9.40	22.09	24.38	3.81	37.84
SRPC - 16 - 8	1	1/2	9.40	28.44	24.38	4.82	42.67
SRPC - 16 - 12	1	3/4	14.80	28.44	25.90	4.06	43.43

## Installation Instructions

### Port Connector

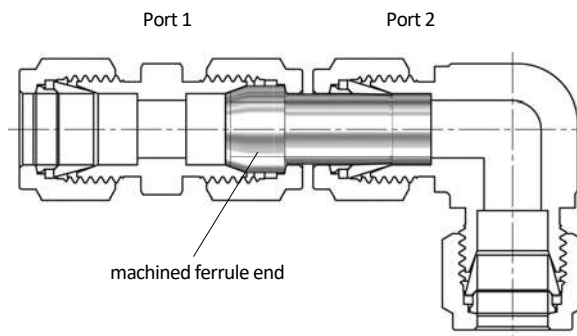

- Remove nut and ferrules from the first of two SUPERLOK ports to be connected.
- Slip nut ( no ferrules) over machined ferrule end of port connector.
- Insert port connector into SUPERLOK port 1 and snug by hand.  
Tighten with wrench 1/4 turn only. For 1/8 and 3/16 in., 2, 3, and 4mm tube fittings, tighten only 1/8 turn. Subsequent connections are made by tightening slightly with a wrench after snugging the nut by hand.
- Insert other end of port connector into SUPERLOK port 2 and tighten nut 1-1/4 turns from finger-tight. For 1/16, 1/8 and 3/16 in., 2, 3, and 4mm tube fittings, only 3/4 turn from finger-tight is necessary.

- Dimensions and Drawings are for reference only and are subject to change without prior notice.  
 - Unless otherwise specified, all dimensions are in millimeters.  
 - Sizes, pressure classes, and end connections not listed are available upon request.  
 - Dimensions shown with SUPERLOK nuts finger-tight, where applicable.



# SFTC

## Lap Joint Flange Tube Connector

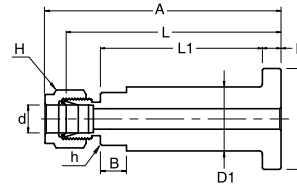

### Connects Fractional Tubes

Part No.	Tube Size (inch)	Flange Seat	Dimensions									
			A	B	L1	L	I	h (inch)	H (inch)	D	D1	d (Min)
SFTC - 4 - SM	1/4	SM	80.8	8.9	56.5	74.9	6.5	11/16	9/16	34.5	21.1	4.8
SFTC - 4 - SR	1/4	SR	80.8	8.9	56.5	74.9	6.5	11/16	9/16	34.5	21.1	4.8
SFTC - 6 - SM	3/8	SM	82.3	8.9	56.5	74.9	6.5	11/16	11/16	34.5	21.1	7.1
SFTC - 6 - SR	3/8	SR	82.3	8.9	56.5	74.9	6.5	11/16	11/16	34.5	21.1	7.1
SFTC - 8 - SM	1/2	SM	85.1	8.9	56.5	74.9	6.5	3/4	7/8	34.5	21.1	10.4
SFTC - 8 - SR	1/2	SR	85.1	8.9	56.5	74.9	6.5	3/4	7/8	34.5	21.1	10.4

Lap joint flange tube connector provides easy joint between process lines and instruments designed for use with 1/2in Lap joint flanges to ANSI B 16.5 or BS 1560

### Flange Seal Finish

Two surface finishes, smooth or serrated, are available on the sealing surface of the stub end.



**Smooth**  
Identifier : SM  
Ra 3.2 ~ 6.3  
micrometer



**Serrated**  
Identifier : SR  
Ra 6.3 ~ 12.5  
micrometer

\*Note : GROOVE identifies serrated surface finish

# SAF

## An Flare

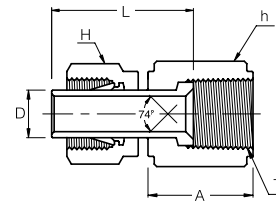

### Connects Fractional SUPERLOK® Port To Male AN

Part No.	Tube O.D. D (inch)	AN Tube Flare Size (inch)	Straight Thread T (U)	Width Across Flat		A	L
				h (inch)	H (inch)		
SAF - 2 - 2U	1/8	1/8	5/16-24	3/8	7/16	13.71	18.54
SAF - 2 - 4U	1/8	1/4	7/16-20	9/16	7/16	15.74	19.05
SAF - 4 - 4U	1/4	1/4	7/16-20	9/16	9/16	15.74	23.20
SAF - 6 - 6U	3/8	3/8	9/16-18	11/16	11/16	18.28	27.30
SAF - 8 - 8U	1/2	1/2	3/4-16	7/8	7/8	21.59	34.50

- Dimensions and Drawings are for reference only and are subject to change without prior notice.
- Unless otherwise specified, all dimensions are in millimeters.
- Sizes, pressure classes, and end connections not listed are available upon request.
- Dimensions shown with SUPERLOK nuts finger-tight, where applicable.

# SAU

An Union

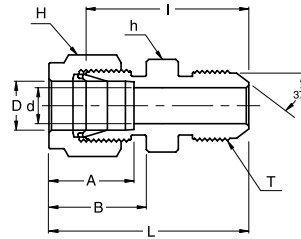

## Connects Fractional Tubes To An Flared Tubes

Part No.	Tube OD D (inch)	AN Tube Flare Size (inch)	Straight Thread T (U)	d Min	Width Across Flat		A	B	I	L
					h (inch)	H (inch)				
SAU - 2 - 2U	1/8	1/8	5/16-24	1.52	7/16	7/16	12.70	15.24	25.65	32.25
SAU - 2 - 4U	1/8	1/4	7/16-20	2.28	1/2	7/16	12.70	15.24	28.44	35.05
SAU - 4 - 4U	1/4	1/4	7/16-20	4.31	1/2	9/16	15.24	17.78	30.22	37.59
SAU - 5 - 5U	5/16	5/16	1/2-20	5.84	9/16	5/8	16.25	18.54	30.98	38.35
SAU - 6 - 4U	3/8	1/4	7/16-20	4.31	5/8	11/16	16.76	19.30	32.25	39.62
SAU - 6 - 6U	3/8	3/8	9/16-18	7.11	5/8	11/16	16.76	19.30	32.25	39.62
SAU - 8 - 8U	1/2	1/2	3/4-16	9.90	13/16	7/8	22.86	21.84	35.81	45.97
SAU - 12 - 12U	3/4	3/4	1-1/16-12	15.49	1-1/8	1-1/8	24.38	21.84	43.18	53.34
SAU - 16 - 16U	1	1	1-5/16-12	21.33	1-3/8	1-1/2	31.24	26.41	49.27	61.46

# SAA

An Adapter

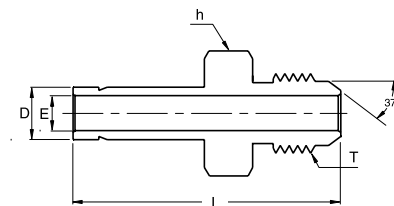

## Connects Fractional SUPERLOK® Port To AN Flared Tubes

Part No.	Tube OD D (inch)	AN Tube Flare Size (inch)	Straight Thread T (U)	Width Across Flat h (inch)	E	L
SAA - 4 - 4U	1/4	1/4	7/16-20	1/2	4.40	37.08
SAA - 6 - 4U	3/8	1/4	7/16-20	1/2	6.90	38.86
SAA - 6 - 6U	3/8	3/8	9/16-18	5/8	6.90	39.62
SAA - 8 - 8U	1/2	1/2	3/4-16	13/16	9.40	48.51
SAA - 12 - 12U	3/4	3/4	1-1/16-12	1-1/8	14.80	56.13
SAA - 16 - 16U	1	1	1-5/16-12	1-3/8	20.40	65.53

- Dimensions and Drawings are for reference only and are subject to change without prior notice.
- Unless otherwise specified, all dimensions are in millimeters.
- Sizes, pressure classes, and end connections not listed are available upon request.
- Dimensions shown with SUPERLOK nuts finger-tight, where applicable.

## SOSC

### O-ring Straight Thread Connector

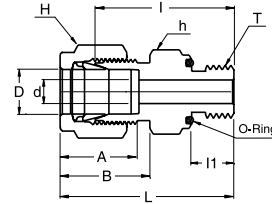

#### Connects Fractional Tube To Female Straight Thread

Part No.	Tube OD D (inch)	Straight Thread T (U)	d Min	Width Across Flat		A	B	I	I1	L	O-Ring Uniform Size Number
				h (inch)	H (inch)						
SOSC - 2 - 2U	1/8	5/16-24	2.28	9/16	7/16	12.70	15.24	26.16	8.63	32.76	-011
SOSC - 3 - 3U	3/16	3/8-24	3.05	5/8	1/2	13.71	16.00	27.68	9.65	34.29	-012
SOSC - 4 - 4U	1/4	7/16-20	4.82	3/4	9/16	15.24	17.78	30.98	10.41	38.35	-111
SOSC - 5 - 5U	5/16	1/2-20	6.35	7/8	5/8	16.25	18.54	33.27	11.17	40.64	-112
SOSC - 6 - 6U	3/8	9/16-18	7.11	15/16	11/16	16.76	19.30	35.05	11.93	42.41	-114
SOSC - 8 - 8U	1/2	3/4-16	10.41	1-1/8	7/8	22.86	21.84	35.81	11.93	45.97	-116
SOSC -12 - 12U	3/4	1-1/16-12	15.75	1-1/2	1-1/8	24.38	21.84	42.16	14.22	52.32	-215
SOSC -16 - 16U	1	1-5/16-12	22.35	1-3/4	1-1/2	31.24	26.41	45.97	14.22	58.16	-219

## SOPC

### O-Seal Pipe Thread Connector

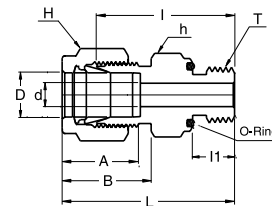

#### Connects Fractional Tube To Female NPT Thread

Part No.	Tube OD D (inch)	T* (NPT)	d Min	Width Across Flat		A	B	I	I1	L	O-Ring Uniform Size Number
				h (inch)	H (inch)						
SOPC - 2 - 2N	1/8	1/8	2.28	3/4	7/16	12.70	15.24	26.16	7.11	32.76	-111
SOPC - 4 - 2N	1/4	1/8	4.82	3/4	9/16	15.24	17.78	27.68	7.11	35.05	-111
SOPC - 4 - 4N	1/4	1/4	4.82	15/16	9/16	15.24	17.78	30.98	9.65	38.35	-113
SOPC - 6 - 4N	3/8	1/4	7.11	15/16	11/16	16.76	19.30	32.51	9.65	39.87	-113
SOPC - 6 - 6N	3/8	3/8	7.11	1-1/8	11/16	16.76	19.30	34.03	10.41	41.40	-116
SOPC - 6 - 8N	3/8	1/2	7.11	1-5/16	11/16	16.76	19.30	39.62	13.46	46.99	-212
SOPC - 8 - 8N	1/2	1/2	10.41	1-5/16	7/8	22.86	21.84	39.62	13.46	49.78	-212

- Dimensions and Drawings are for reference only and are subject to change without prior notice.
- Unless otherwise specified, all dimensions are in millimeters.
- Sizes, pressure classes, and end connections not listed are available upon request.
- Dimensions shown with SUPERLOK nuts finger-tight, where applicable.

# SSMC

## SAE/MS Male Connector

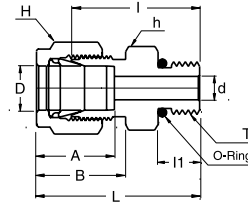
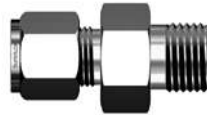

### Connects Fractional Tubes To SAE/MS Straight Thread Boss

Part No.	Tube OD D (inch)	Straight Thread T (U)	d Min	Width Across Flat		A	B	I	I1	L	O-Ring Uniform Size Number
				h (inch)	H (inch)						
SSMC - 2 - 2U	1/8	5/16-24	2.28	7/16	7/16	12.70	15.24	23.36	7.62	29.97	3-902
SSMC - 4 - 4U	1/4	7/16-20	4.82	9/16	9/16	15.24	17.78	26.67	9.14	34.03	3-904
SSMC - 4 - 6U	1/4	9/16-18	4.82	11/16	9/16	15.24	17.78	28.19	9.90	35.56	3-906
SSMC - 4 - 8U	1/4	3/4-16	4.82	7/8	9/16	15.24	17.78	30.22	11.17	37.59	3-908
SSMC - 4 - 10U	1/4	7/8-14	4.82	1	9/16	15.24	17.78	33.27	12.70	40.64	3-910
SSMC - 5 - 5U	5/16	1/2-20	6.35	5/8	5/8	16.25	18.54	27.43	9.14	34.79	3-905
SSMC - 6 - 4U	3/8	7/16-20	5.08	5/8	11/16	16.76	19.30	28.19	9.14	35.56	3-904
SSMC - 6 - 6U	3/8	9/16-18	7.11	11/16	11/16	16.76	19.30	29.71	9.90	37.08	3-906
SSMC - 6 - 8U	3/8	3/4-16	7.11	7/8	11/16	16.76	19.30	31.75	11.17	39.11	3-908
SSMC - 6 - 10U	3/8	7/8-14	7.11	1	11/16	16.76	19.30	34.79	12.70	42.16	3-910
SSMC - 8 - 6U	1/2	9/16-18	7.11	13/16	7/8	22.86	21.84	28.95	9.90	39.11	3-906
SSMC - 8 - 8U	1/2	3/4-16	10.41	7/8	7/8	22.86	21.84	31.75	11.17	41.91	3-908
SSMC - 8 - 10U	1/2	7/8-14	10.41	1	7/8	22.86	21.84	34.79	12.70	44.95	3-910
SSMC - 8 - 12U	1/2	1-1/16-12	10.41	1-1/4	7/8	22.86	21.84	38.86	14.98	49.02	3-912
SSMC - 10 - 8U	5/8	3/4-16	10.66	15/16	1	24.38	21.84	31.75	11.17	41.91	3-908
SSMC - 10 - 10U	5/8	7/8-14	12.70	1	1	24.38	21.84	35.05	12.70	45.21	3-910
SSMC - 12 - 8U	3/4	3/4-16	10.66	1-1/16	1-1/8	24.38	21.84	35.81	11.17	45.97	3-908
SSMC - 12 - 12U	3/4	1-1/16-12	15.74	1-1/4	1-1/8	24.38	21.84	38.86	14.98	49.02	3-912
SSMC - 14 - 14U	7/8	1-3/16-12	18.28	1-3/8	1-1/4	25.90	21.84	38.86	14.98	49.02	3-914
SSMC - 16 - 12U	1	1-1/16-12	16.76	1-3/8	1-1/2	31.24	26.41	41.14	14.98	53.34	3-912
SSMC - 16 - 16U	1	1-5/16-12	22.35	1-1/2	1-1/2	31.24	26.41	42.16	14.98	54.35	3-916

- Dimensions and Drawings are for reference only and are subject to change without prior notice.
- Unless otherwise specified, all dimensions are in millimeters.
- Sizes, pressure classes, and end connections not listed are available upon request.
- Dimensions shown with SUPERLOK nuts finger-tight, where applicable.

## Mounting Dimensions for O-Seal Connectors

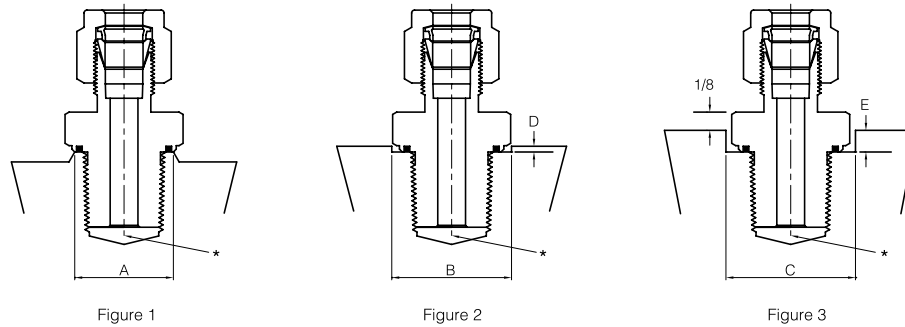

\*ALLOW CLEARANCE FOR FULL THREAD

### Installation Instruction

In order to prevent the leakage with SUPERLOK O-Seal Fittings, the surface perpendicular to the axis of the thread should be flat. When installing an O-Seal fitting, turn it until finger-tight. (The squeeze on O-Ring can be felt during the last 1/4 turn). After finger-tight installation, snug lightly with a wrench.

When connecting the tubing to the SUPERLOK connector, always use a back-up wrench on the O-Seal fitting hex so it does not turn while the nut is being tightened. Also use a back-up wrench when disconnecting a tubing connection.

For a raised surface, such as Figure 1, it is recommended that the flat surface have a diameter at least as large as dimension “A” for the various size O-Seal fittings. This diameter is sufficient to allow metal-to-metal contact outside of the O-Ring sealing diameter and to prevent O-Ring extrusion at high pressure.

Figure 2 is an O-Seal fitting using with a counter bored or recessed hole. In this case, the diameter “B” is sufficient to allow the round shoulder of the O-seal to clear for proper installation. “D” gives the maximum depth that can be used with this diameter.

Figure 3 shows the usage at deeper grooved or concaved area and “E” is the maximum depth that will allow a thin wrench(1/8”) to hold the O-Seal fitting while the SUPERLOK connection is made to the tubing. The diameter “C” is sufficient to allow the hex of the fitting to turn in the recessed hole.

Basic Ordering Number	Straight Thread	Pipe Thread	A Min. Dia.	B Min. Dia.	C Min. Dia.	D Min. Dia.	E Min. Dia.
SOSC - 1 - 2U	5/16-24	-	12.7	15.0	16.8	2.3	4.1
SOSC - 2 - 2U	5/16-24	-	12.7	15.0	16.8	2.3	5.6
SOPC - 2 - 2N	-	1/8 NPT	17.5	19.8	22.4	4.1	7.1
SOSC - 3 - 3U	3/8-24	-	14.2	16.8	19.1	2.3	5.6
SOSC - 4 - 4U	7/16-20	-	17.5	19.8	22.4	4.1	7.1
SOPC - 4 - 2N	-	1/8 NPT	17.5	19.8	22.4	4.1	7.1
SOPC - 4 - 4N	-	1/4 NPT	22.1	24.6	27.7	4.1	7.9
SOSC - 5 - 5U	1/2-20	-	19.1	23.1	26.2	4.1	7.9
SOSC - 6 - 6U	9/16-18	-	20.6	24.6	27.7	4.1	7.9
SOPC - 6 - 4N	-	1/4 NPT	22.1	24.6	27.7	4.1	7.9
SOPC - 6 - 6N	-	3/8 NPT	25.4	29.5	33.3	4.1	8.6
SOPC - 6 - 8N	-	1/2 NPT	31.0	34.0	38.9	5.6	11.2
SOSC - 8 - 8U	3/4-16	-	25.4	29.5	33.3	4.1	8.6
SOPC - 8 - 8N	-	1/2 NPT	31.0	34.0	38.9	5.6	11.2
SOSC - 12 - 12U	1-1/16-12	-	35.8	38.9	44.5	5.6	12.7
SOSC - 16 - 16U	1-5/16-12	-	42.9	45.2	51.6	5.6	14.2

- Dimensions and Drawings are for reference only and are subject to change without prior notice.
- Unless otherwise specified, all dimensions are in millimeters.
- Sizes, pressure classes, and end connections not listed are available upon request.
- Dimensions shown with SUPERLOK nuts finger-tight, where applicable.

## SAE/MS Straight Thread Positionable Elbows and Tees



### Installation instructions

1. Lubricate O-Ring with the lubricant which is applicable for the system fluid, environment and O-Ring material. (Standard O-Ring materials is viton. Other O-Ring materials are also available).
2. Turn the fittings into the straight thread boss until the metal back- up washer contacts the face of the boss. At this moment, O-Ring gets into inclined groove.
3. Until SUPERLOK's end is oriented in the proper direction, position the fittings by turning to counter clockwise. (no more than 1 turning)
4. Until the washer contacts to the face of the bosses, tighten the fittings with wrench and back-up wrench .

※ Note: SAE/MS's POSITIONABLE TEE and ELBOWS shall be compatible with SAE J1926, MS16142, or O-Ring female straight thread for JIS boss.

## O-Ring for SAE/MS Fittings Bosses

Thread size	Inside Dimension (mm)	Cross Section (mm)	O-Ring Size No.	Thread size	Inside Dimension (mm)	Cross Section (mm)	O-Ring Size No.
5/16-24	6.07	1.63	3-902	3/4-16	16.36	2.21	3-908
3/8-24	7.65	1.63	3-903	7/8-14	19.18	2.46	3-910
7/16-20	8.92	1.83	3-904	1-1/16-12	23.47	2.95	3-912
1/2-20	10.52	1.83	3-905	1-3/16-12	26.59	2.95	3-914
9/16-18	11.89	1.98	3-906	1-5/16-12	29.74	2.95	3-916

- Dimensions and Drawings are for reference only and are subject to change without prior notice.
- Unless otherwise specified, all dimensions are in millimeters.
- Sizes, pressure classes, and end connections not listed are available upon request.
- Dimensions shown with SUPERLOK nuts finger-tight, where applicable.

## SAE/MS Internal Straight Thread Boss

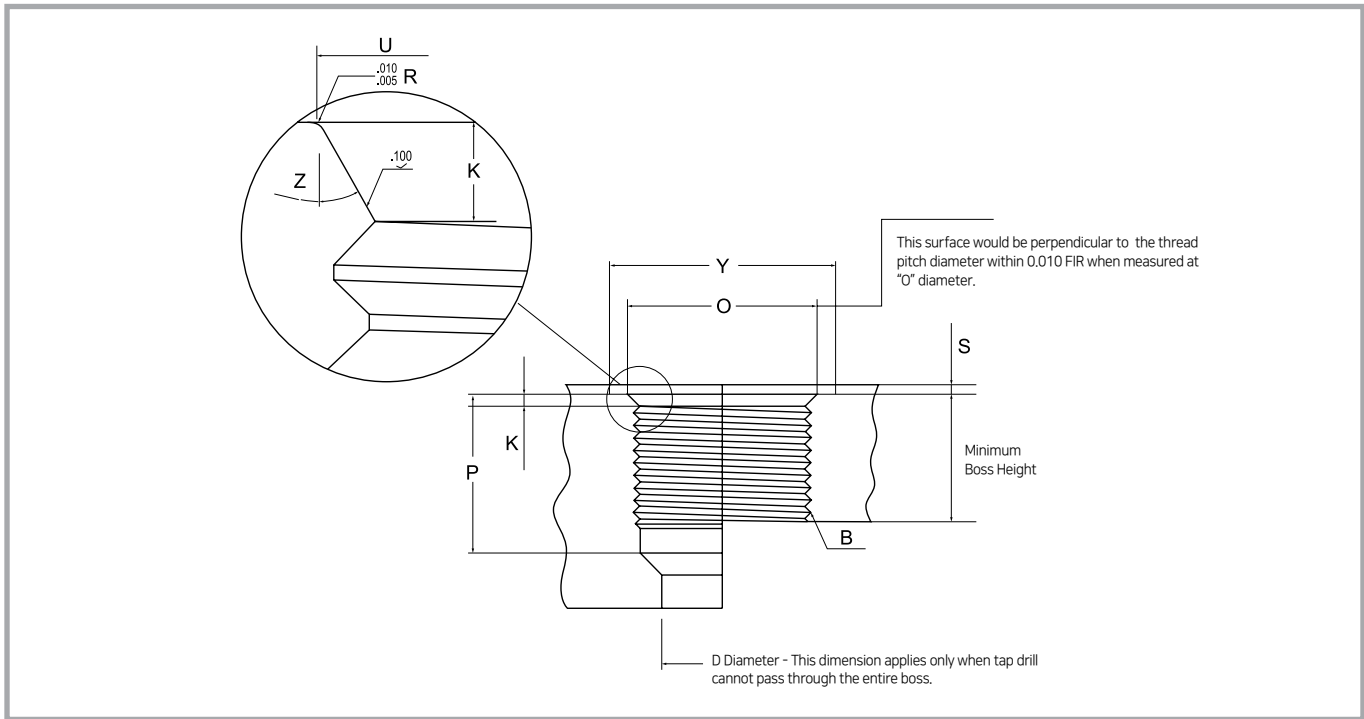

### Data for SAE/MS Straight Thread Boss

Nom. Tube O.D	Thread Size	B / Straight Thread				D Dia	Full Thread Depth	K	O Dia	P <sup>④</sup>	S <sup>②③</sup>	U <sup>②</sup> Dia	Y <sup>①</sup> Dia	Z
		Pitch Dia		Minor Dia										
		Min	Max	Min	Max									
1/8	5/16 - 24	0.2854	0.2902	0.267	0.277	0.062	0.390	0.074	0.438	0.468	0.062	0.358	0.672	12
3/16	3/8 - 24	0.3479	0.3528	0.330	0.340	0.125	0.390	0.074	0.500	0.468	0.062	0.421	0.750	12
1/4	7/16 - 20	0.4050	0.4104	0.383	0.395	0.172	0.454	0.093	0.563	0.547	0.062	0.487	0.828	12
5/16	1/2 - 20	0.4675	0.4731	0.446	0.457	0.234	0.454	0.093	0.625	0.547	0.062	0.550	0.906	12
3/8	9/16 - 18	0.5624	0.5323	0.502	0.515	0.297	0.500	0.097	0.688	0.609	0.062	0.616	0.969	12
1/2	3/4 - 16	0.7094	0.7159	0.682	0.696	0.391	0.562	0.100	0.875	0.688	0.094	0.811	1.188	15
5/8	7/8 - 14	0.8286	0.8356	0.798	0.614	0.484	0.656	0.100	1.000	0.781	0.094	0.942	1.344	15
3/4	1-1/16 - 12	1.0084	1.0158	0.972	0.990	0.609	0.750	1.130	1.250	0.906	0.094	1.148	1.625	15
7/8	1-3/16 - 12	1.1334	1.1409	1.097	1.115	0.719	0.750	1.130	1.375	0.906	0.094	1.273	1.765	15
1	1-5/16 - 12	1.2584	1.2659	1.222	1.240	0.844	0.750	0.130	1.500	0.906	0.125	1.398	1.910	15
1-1/4	1-5/8 - 12	1.5709	1.5785	1.535	1.553	1.078	0.750	0.132	1.875	0.906	0.125	1.713	2.270	15
1-1/2	1-7/8 - 12	1.8209	1.8287	1.785	1.803	1.312	0.750	0.132	2.125	0.906	0.125	1.962	2.560	15
2	2-1/2 - 12	2.4459	2.4540	2.410	2.428	1.781	0.750	0.132	2.750	0.906	0.125	2.587	3.480	15

- ① Diameter U shall be concentric with thread pitch diameter within 0.005 full indicator reading (FIR) and shall be free from longitudinal and spiral tool marks. Annular tool marks shall be less than 100micro inches.
- ② This is the maximum recommended spotface depth to permit sufficient wrench grip for proper tightening of the fitting or locknut
- ③ If the surface of boss surface is machined, dimensions Y and S does not need to be applied.
- ④ Bottoming tap shall be used to satisfy the tap drill depth. Where standard taps are used, the drill depths must be increased accordingly.

- Dimensions and Drawings are for reference only and are subject to change without prior notice.  
 - Unless otherwise specified, all dimensions are in millimeters.  
 - Sizes, pressure classes, and end connections not listed are available upon request.  
 - Dimensions shown with SUPERLOK nuts finger-tight, where applicable.

# SPWC

## Male Pipe Weld Connector

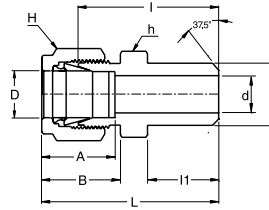

### Connects Fractional Tubes To Pipe

Part No.	Tube O.D. D (inch)	Male Pipe Size P		d Min	Width Across Flat		A	B	I	I1	L
		Nom.	O.D.		h (inch)	H (inch)					
SPWC - 2 - 2P	1/8	1/8	10.30	2.28	7/16	7/16	12.70	15.24	23.87	9.65	30.48
SPWC - 3 - 2P	3/16	1/8	10.30	3.04	7/16	1/2	13.71	16.00	24.63	9.65	31.24
SPWC - 4 - 2P	1/4	1/8	10.30	4.82	1/2	9/16	15.24	17.78	25.40	9.65	32.76
SPWC - 4 - 4P	1/4	1/4	13.70	4.82	9/16	9/16	15.24	17.78	30.48	14.22	37.84
SPWC - 5 - 2P	5/16	1/8	10.30	5.08	9/16	5/8	16.25	18.54	26.67	9.65	34.03
SPWC - 5 - 4P	5/16	1/4	13.70	6.35	9/16	5/8	16.25	18.54	31.24	14.22	38.60
SPWC - 6 - 4P	3/8	1/4	13.70	7.11	5/8	11/16	16.76	19.30	32.51	14.22	39.87
SPWC - 6 - 6P	3/8	3/8	17.10	7.11	11/16	11/16	16.76	19.30	32.51	14.22	39.87
SPWC - 6 - 8P	3/8	1/2	21.30	7.11	7/8	11/16	16.76	19.30	38.86	19.05	46.22
SPWC - 8 - 6P	1/2	3/8	17.10	10.41	13/16	7/8	22.86	21.84	33.27	14.22	43.43
SPWC - 8 - 8P	1/2	1/2	21.30	10.41	7/8	7/8	22.86	21.84	38.86	19.05	49.02
SPWC - 8 - 12P	1/2	3/4	26.67	10.41	1-1/16	7/8	22.86	21.84	40.38	19.05	50.54
SPWC - 10 - 8P	5/8	1/2	21.30	12.70	15/16	1	24.38	21.84	38.86	19.05	49.02
SPWC - 12 - 12P	3/4	3/4	26.67	15.74	1-1/16	1-1/8	24.38	21.84	40.38	19.05	50.54
SPWC - 16 - 16P	1	1	33.40	22.35	1-3/8	1-1/2	31.24	26.41	50.03	23.87	62.23

### Connects Metric Tubes To Pipe

Part No.	Tube O.D. D	Male Pipe Size P		d Min	Width Across Flat		A	B	I	I1	L
		Nom.	O.D.		h	H					
SPWC - 3M - 2P	3	1/8	10.3	2.4	12	12	12.9	15.3	23.9	9.7	30.5
SPWC - 4M - 2P	4	1/8	10.3	2.4	12	12	13.7	16.1	24.6	9.7	31.2
SPWC - 6M - 2P	6	1/8	10.3	4.8	14	14	15.3	17.7	25.4	9.7	32.8
SPWC - 6M - 4P	6	1/4	13.7	4.8	14	14	15.3	17.7	30.5	14.2	37.9
SPWC - 8M - 2P	8	1/8	10.3	5.1	15	16	16.2	18.6	26.7	9.7	34.2
SPWC - 8M - 4P	8	1/4	13.7	6.4	15	16	16.2	18.6	31.2	14.2	38.7
SPWC - 8M - 8P	8	1/2	21.3	6.4	22	16	16.2	18.6	38.1	19.0	45.6
SPWC - 10M - 4P	10	1/4	13.7	7.1	18	19	17.2	19.5	33.3	14.2	40.9
SPWC - 10M - 6P	10	3/8	17.1	7.9	18	19	17.2	19.5	33.3	14.2	40.9
SPWC - 10M - 8P	10	1/2	21.3	7.9	22	19	17.2	19.5	38.9	19.0	46.5
SPWC - 12M - 4P	12	1/4	13.7	7.1	22	22	22.8	22.0	33.3	14.2	43.4
SPWC - 12M - 6P	12	3/8	17.1	9.5	22	22	22.8	22.0	33.3	14.2	43.4
SPWC - 12M - 8P	12	1/2	21.3	9.5	22	22	22.8	22.0	38.9	19.0	49.0
SPWC - 15M - 8P	15	1/2	21.3	11.9	24	25	24.4	22.0	38.9	19.0	49.0
SPWC - 16M - 8P	16	1/2	21.3	12.7	24	25	24.4	22.0	38.9	19.0	49.0
SPWC - 18M - 8P	18	1/2	21.3	13.5	27	30	24.4	22.0	40.4	19.0	50.5

Note : SUPERLOK® weld ends are constructed per schedule 80 wall thickness or greater. Weld End : ANSI B31.1 and B31.3

### Weld end SUPERLOK® Usage Informations :

- Do weld after removing nut and ferrules from body to protect them from weld heat.
- Do protect thread end or pot and seat area of SUPERLOK® body with another nut and plug.(for easy disassembly just finger tighten it)
- Correct weld procedure is required during welding and after weld completion. suitable heat treatment must be carried out in accordance with industry or your own standard.

- Dimensions and Drawings are for reference only and are subject to change without prior notice.
- Unless otherwise specified, all dimensions are in millimeters.
- Sizes, pressure classes, and end connections not listed are available upon request.
- Dimensions shown with SUPERLOK nuts finger-tight, where applicable.



## SMPWE

### Male Pipe Weld Elbow

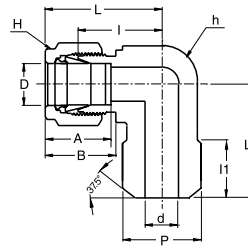

#### Connects Fractional Tubes To Pipe

Part No.	Tube OD D (inch)	Pipe Size (P)		d Min	Width Across Flat		A	B	I	I1	L	L1
		Nom.	O.D.		h (inch)	H (inch)						
SMPWE - 4 - 4P	1/4	1/4	13.70	4.82	1/2	9/16	15.24	17.78	19.55	14.22	26.90	23.37
SMPWE - 6 - 4P	3/8	1/4	13.70	7.11	5/8	11/16	16.76	19.30	23.11	14.22	30.48	25.40
SMPWE - 8 - 8P	1/2	1/2	21.30	10.41	13/16	7/8	22.86	21.84	25.90	19.05	36.06	33.02

## SSWC

### Tube Socket Weld Connector

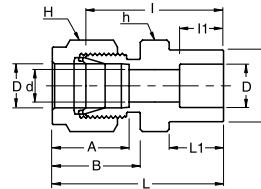

#### Connects Fractional Tubes

Part No.	Tube OD D (inch)	d Min	P	Width Across Flat		A	B	I	I1	L	L1
				h (inch)	H (inch)						
SSWC - 2	1/8	2.28	7.87	7/16	7/16	12.70	15.24	22.35	6.35	28.95	8.63
SSWC - 4	1/4	4.82	11.17	1/2	9/16	15.24	17.78	26.16	7.87	33.52	10.41
SSWC - 6	3/8	7.11	15.74	5/8	11/16	16.76	19.30	30.22	9.65	37.59	11.93
SSWC - 8	1/2	10.41	19.05	13/16	7/8	22.86	21.84	30.98	12.70	41.14	11.93
SSWC - 12	3/4	15.74	26.67	1-1/16	1-1/8	24.38	21.84	33.27	14.22	43.43	11.93
SSWC - 16	1	22.35	33.27	1-3/8	1-1/2	31.24	26.41	40.38	19.05	52.57	14.22

## SSWE

### Tube Socket Weld Elbow

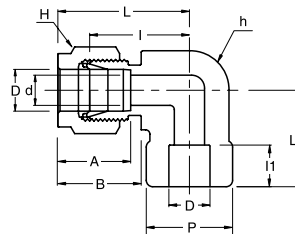

#### Connects Fractional Tubes

Part No.	Tube OD D (inch)	d Min	P	Width Across Flat		A	B	I	I1	L	L1
				h (inch)	H (inch)						
SSWE - 4	1/4	4.82	12.70	1/2	9/16	15.24	17.78	19.55	7.87	26.92	19.55
SSWE - 6	3/8	7.11	15.75	5/8	11/16	16.76	19.30	23.11	9.65	30.48	23.11
SSWE - 8	1/2	10.41	20.57	13/16	7/8	22.86	21.84	25.90	12.70	36.06	25.90
SSWE - 12	3/4	15.74	26.92	1-1/16	1-1/8	24.38	21.84	29.71	14.22	39.87	29.71
SSWE - 16	1	22.35	35.05	1-3/8	1-1/2	31.24	26.41	36.83	19.05	49.02	36.83

- Dimensions and Drawings are for reference only and are subject to change without prior notice.
- Unless otherwise specified, all dimensions are in millimeters.
- Sizes, pressure classes, and end connections not listed are available upon request.
- Dimensions shown with SUPERLOK nuts finger-tight, where applicable.

# SP

## Plug

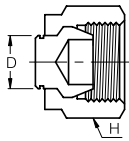

Plug provides plugging fitting port

**Installation instruction**

1. With wrench, 1/4 turn from finger-tight position.  
(1/8 turn for 1/8", 3/16", 2, 3, 4 size plug)
2. Remove nut and ferrules from body

## Fractional

Part No.	Tube OD D (inch)	Width Across Flat H (inch)	Part No.	Tube OD D (inch)	Width Across Flat H (inch)
SP - 2	1/8	7/16	SP - 8	1/2	7/8
SP - 3	3/16	1/2	SP - 10	5/8	1
SP - 4	1/4	9/16	SP - 12	3/4	1-1/8
SP - 5	5/16	5/8	SP - 14	7/8	1-1/4
SP - 6	3/8	11/16	SP - 16	1	1-1/2

Plugs Unused port of Metric SUPERLOK fittings

## Metric

Part No.	Tube OD D (inch)	Width Across Flat H	Part No.	Tube OD D (inch)	Width Across Flat H
SP - 2M	2	12	SP - 15M	15	25
SP - 3M	3	12	SP - 16M	16	25
SP - 4M	4	12	SP - 18M	18	30
SP - 6M	6	14	SP - 20M	20	32
SP - 8M	8	16	SP - 22M	22	32
SP - 10M	10	19	SP - 25M	25	38
SP - 12M	12	22			

Plugs Unused port of Fractional SUPERLOK fittings

# SC

## Cap

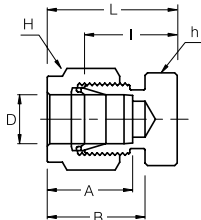

**Installation instruction**

1. With wrench, 1-1/4 turn from finger-tight position.  
(3/4 turn for 1/8", 3/16", 3mm, 4mm)
2. Insert tube end into cap

## Connects Caps End of Fractional Tubes

Part No.	Tube OD D (inch)	Width Across Flat		A	B	I	L
		h (inch)	H (inch)				
SC - 1	1/16	5/16	5/16	8.63	10.92	11.20	14.98
SC - 2	1/8	7/16	7/16	12.70	15.24	13.46	20.06
SC - 3	3/16	7/16	1/2	13.71	16.00	14.73	21.33
SC - 4	1/4	1/2	9/16	15.24	17.78	16.00	23.36
SC - 5	5/16	9/16	5/8	16.25	18.54	17.01	24.38
SC - 6	3/8	5/8	11/16	16.76	19.30	18.28	25.65
SC - 8	1/2	13/16	7/8	22.86	21.84	19.05	29.21
SC - 10	5/8	15/16	1	24.38	21.84	19.81	29.97
SC - 12	3/4	1-1/16	1-1/8	24.38	21.84	23.33	33.49
SC - 14	7/8	1-3/16	1-1/4	25.90	21.84	23.87	34.03
SC - 16	1	1-3/8	1/1/2	31.24	26.41	26.16	38.35

## Connects Metric Tubes

Part No.	Tube O.D. D	Width Across Flat		A	B	I	L	Part No.	Tube O.D. D	Width Across Flat		A	B	I	L
		h	H							h	H				
SC - 2M	2	12	12	12.9	15.3	13.5	20.1	SC - 15M	15	24	25	24.4	22.0	19.8	29.9
SC - 3M	3	12	12	12.9	15.3	13.5	20.1	SC - 16M	16	24	25	24.4	22.0	19.8	29.9
SC - 4M	4	12	12	13.7	16.1	14.7	21.3	SC - 18M	18	27	30	24.4	22.0	21.3	31.4
SC - 6M	6	14	14	15.3	17.7	15.7	23.1	SC - 20M	20	30	32	26.0	22.0	23.9	34.0
SC - 8M	8	15	16	16.2	18.6	17.0	24.5	SC - 22M	22	30	32	26.0	22.0	23.9	34.0
SC - 10M	10	18	19	17.2	19.5	19.0	26.6	SC - 25M	25	35	38	31.3	26.5	26.2	38.5
SC - 12M	12	22	22	22.8	22.0	19.0	29.1								

- Dimensions and Drawings are for reference only and are subject to change without prior notice.  
 - Unless otherwise specified, all dimensions are in millimeters.  
 - Sizes, pressure classes, and end connections not listed are available upon request.  
 - Dimensions shown with SUPERLOK nuts finger-tight, where applicable.

**SN**

Nut

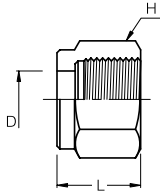

**Fractional**

Part No.	Tube OD D (inch)	Width Across Flat H (inch)	L	Part No.	Tube OD D (inch)	Width Across Flat H (inch)	L
SN - 1	1/16	5/16	7.90	SN - 8	1/2	7/8	17.30
SN - 2	1/8	7/16	11.93	SN - 10	5/8	1	17.52
SN - 3	3/16	1/2	11.93	SN - 12	3/4	1-1/8	17.52
SN - 4	1/4	9/16	12.70	SN - 14	7/8	1-1/4	17.52
SN - 5	5/16	5/8	13.50	SN - 16	1	1-1/2	20.60
SN - 6	3/8	11/16	14.22				

**Metric**

Part No.	Tube OD D	Width Across Flat H	L	Part No.	Tube OD D	Width Across Flat H	L
SN - 2M	2	12	11.90	SN - 14M	14	25	17.50
SN - 3M	3	12	11.90	SN - 15M	15	25	17.50
SN - 4M	4	12	11.90	SN - 16M	16	25	17.50
SN - 6M	6	14	12.70	SN - 18M	18	30	17.50
SN - 8M	8	16	13.50	SN - 20M	20	32	17.50
SN - 10M	10	19	15.10	SN - 22M	22	32	17.50
SN - 12M	12	22	17.50	SN - 25M	25	38	20.60

**SFF**

Front Ferrule

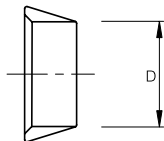

**Fractional**

Part No.	Tube OD D (inch)	Part No.	Tube OD D (inch)
SFF - 1	1/16	SFF - 8	1/2
SFF - 2	1/8	SFF - 10	5/8
SFF - 3	3/16	SFF - 12	3/4
SFF - 4	1/4	SFF - 14	7/8
SFF - 5	5/16	SFF - 16	1
SFF - 6	3/8		

**Metric**

Part No.	Tube OD D	Part No.	Tube OD D
SFF - 2M	2	SFF - 14M	14
SFF - 3M	3	SFF - 15M	15
SFF - 4M	4	SFF - 16M	16
SFF - 6M	6	SFF - 18M	18
SFF - 8M	8	SFF - 20M	20
SFF - 10M	10	SFF - 22M	22
SFF - 12M	12	SFF - 25M	25

- Dimensions and Drawings are for reference only and are subject to change without prior notice.
- Unless otherwise specified, all dimensions are in millimeters.
- Sizes, pressure classes, and end connections not listed are available upon request.
- Dimensions shown with SUPERLOK nuts finger-tight, where applicable.

### SBF

Back Ferrule

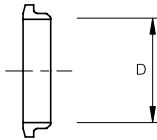

#### Fractional

Part No.	Tube OD D (inch)	Part No.	Tube OD D (inch)	Part No.	Tube OD D (inch)
SBF - 1	1/16	SBF - 5	5/16	SBF - 12	3/4
SBF - 2	1/8	SBF - 6	3/8	SBF - 14	7/8
SBF - 3	3/16	SBF - 8	1/2	SBF - 16	1
SBF - 4	1/4	SBF - 10	5/8		

#### Metric

Part No.	Tube OD D (inch)	Part No.	Tube OD D (inch)	Part No.	Tube OD D (inch)
SBF - 2M	2	SBF - 10M	10	SBF - 18M	18
SBF - 3M	3	SBF - 12M	12	SBF - 20M	20
SBF - 4M	4	SBF - 14M	14	SBF - 22M	22
SBF - 6M	6	SBF - 15M	15	SBF - 25M	25
SBF - 8M	8	SBF - 16M	16		

### SFS

Ferrule Set



#### Fractional

Part No.	Tube OD D (inch)	Part No.	Tube OD D (inch)	Part No.	Tube OD D (inch)
SFS - 1	1/16	SFS - 5	5/16	SFS - 12	3/4
SFS - 2	1/8	SFS - 6	3/8	SFS - 14	7/8
SFS - 3	3/16	SFS - 8	1/2	SFS - 16	1
SFS - 4	1/4	SFS - 10	5/8		

#### Metric

Part No.	Tube OD D (inch)	Part No.	Tube OD D (inch)	Part No.	Tube OD D (inch)
SFS - 2M	2	SFS - 10M	10	SFS - 20M	20
SFS - 3M	3	SFS - 12M	12	SFS - 22M	22
SFS - 4M	4	SFS - 15M	15	SFS - 25M	25
SFS - 6M	6	SFS - 16M	16		
SFS - 8M	8	SFS - 18M	18		

### SI

Insert

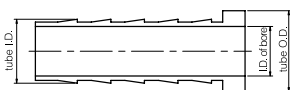

#### Fractional

Part No.	Tube OD D (inch)	Tube I.D. (inch)	I.D. of Bore	Part No.	Tube OD D (inch)	Tube I.D. (inch)	I.D. of Bore
SI - 3 - 2	3/16	1/8	2.28	SI 8 - 4	1/2	1/4	4.82
SI - 4 - 2	1/4	1/8	2.28	SI 8 - 6	1/2	3/8	7.87
SI - 4 - 3	1/4	3/16	3.55	SI 10 - 6	5/8	3/8	7.87
SI - 5 - 2	5/16	1/8	2.28	SI 10 - 8	5/8	1/2	11.17
SI - 5 - 3	5/16	3/16	3.04	SI 12 - 8	3/4	1/2	11.17
SI - 5 - 4	5/16	1/4	4.82	SI 12 - 10	3/4	5/8	14.22
SI - 6 - 3	3/8	3/16	3.04	SI 16 - 12	1	3/4	17.52
SI - 6 - 4	3/8	1/4	4.82				

- Dimensions and Drawings are for reference only and are subject to change without prior notice.
- Unless otherwise specified, all dimensions are in millimeters.
- Sizes, pressure classes, and end connections not listed are available upon request.
- Dimensions shown with SUPERLOK nuts finger-tight, where applicable.

## SBHR

### Bulkhead Retainer

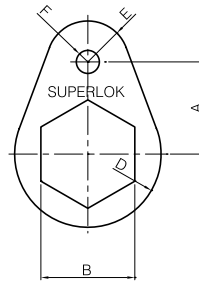

Part No.	A (inch)	B (inch)	C (inch)	D Dia (inch)	E Dia (inch)	F Dia (inch)
SBHR - 1	3/8	5/16	1/8	5/16	5/32	5/32
SBHR - 2	1/2	1/2	1/8	13/32	7/32	5/32
SBHR - 3	9/16	9/16	1/8	15/32	1/4	5/32
SBHR - 4 ①	5/8	5/8	1/8	1/2	9/32	5/32
SBHR - 5	1/16	11/16	1/8	9/16	5/16	5/32
SBHR - 6	3/4	3/4	1/8	5/8	11/32	5/32
SBHR - 8 ②	15/16	15/16	1/8	3/4	13/32	7/32
SBHR - 10 ③	1	1-1/16	1/8	13/16	13/32	7/32
SBHR - 12 ④	1-1/16	1-3/16	1/8	29/32	15/32	7/32
SBHR - 14	1-1/8	1-5/16	1/8	1-1/32	17/32	7/32
SBHR - 16	1-9/32	1-5/8	1/8	1-5/32	9/16	7/32
SBHR - 8M	11/16	18 mm	1/8	9/16	5/16	5/32
SBHR - 10M	15/16	22 mm	1/8	3/4	13/32	7/32

- ① Can be used with 6mm bulkheads
- ② Can be used with 12mm bulkheads
- ③ Can be used with 15mm and 16mm bulkheads
- ④ Can be used with 18mm bulkheads

## SVP

### Vent Protector

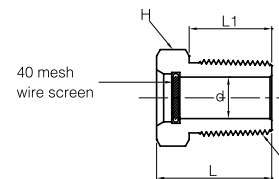

Part No.	T (NPT)	L	L1	d	H (inch)
SVP - 4N	1/4	19.81	14.22	7.11	9/16
SVP - 6N	3/8	20.57	14.22	10.41	11/16
SVP - 8N	1/2	26.16	19.05	12.70	7/8
SVP - 12N	3/4	26.92	19.05	18.29	1-1/16
SVP - 16N	1	33.30	23.90	22.40	1-3/8

- Dimensions and Drawings are for reference only and are subject to change without prior notice.
- Unless otherwise specified, all dimensions are in millimeters.
- Sizes, pressure classes, and end connections not listed are available upon request.
- Dimensions shown with SUPERLOK nuts finger-tight, where applicable.

# Single-Ferrule Tube Fittings

Available in sizes from 1/16 to 1 in

## Features

- Single ferrule swaging action
- Total component interchangeability
- More tolerant of vibrations
- 316 stainless steel construction
- Heat code traceable



## Introduction

SUPERLOK Tube Fitting offers both double-ferrule and single-ferrule tube fittings.

While the double-ferrule design is more popular, there are situations where single-ferrule tube fittings are preferred.

SUPERLOK single-ferrule tube fitting is designed to provide leak-proof, secure connections that can withstand high pressure, vibration and vacuum applications.

This fitting includes single ferrule with body and nut of a standard SUPERLOK tube fitting (double-ferrule design).

## Pressure and Temperature Ratings

SUPERLOK single-ferrule tube fittings are identical to standard SUPERLOK tube fittings in pressure and temperature ratings, and with the same dimensions as the standard SUPERLOK tube fittings.

## Ordering Information

The single-ferrule tube fittings part numbering system is the same as SUPERLOK Tube Fitting (double ferrule design) except that you add an "S" as a suffix to Tube OD designator.

Example :  $\frac{\text{SMC}}{1} - \frac{8S}{2-1} - \frac{8N}{2-2} - \frac{M40}{3}$

### 1. Type of Fitting

Please refer to SUPERLOK tube fitting index on page 2.

#### Examples :

- SMC = male connector
- SME = male elbow
- SU = union
- SUT = union tee

### 3. Material

- (Blank) = 316 Stainless Steel
- 36L = 316L Stainless Steel
- B = Brass
- AL = Aluminum
- 15 = Carbon Steel A105
- S45C = Carbon Steel S45C
- M40 = Monel Alloy 400
- 825 = Alloy 825
- 625 = Alloy 625
- 276 = Alloy C-276

### 2. Size of Fitting

#### 2-1) Tube OD Designator

Tube OD(inch)	1/4	3/8	1/2	3/4	1
Designator	4S	6S	8S	12S	16S

#### 2-2) Pipe Thread Designator

Size(inch)	1/8	1/4	3/8	1/2	3/4	1
ISO Tapered	2R	4R	6R	8R	12R	16R
Screwed NPT	2N	4N	6N	8N	12N	16N
ISO Parallel	2G	4G	6G	8G	12G	16G
Unified Screw	2U	4U	6U	8U	12U	16U

※ For special sizes and configurations, please consult BMT (SUPERLOK) sales representative.

# Swaging Units



## Features

- Compact and rugged table-top unit for mobile and flexible use.
- Manual pressure adjustment with digital display.
- Short assembling times of only few seconds.
- Short set-up times when changing the tube diameter or the working method.
- No initial strain placed on nut or fitting body threads or on body seal surfaces.
- Beeping when pre-swaging is completed.
- Assembly and installation time and operator errors reduced.

## Operating Instructions

### 1. SETUP

- ① Install the die holder into the swaging unit.
- ② Install the appropriate size die head (same size as the fitting).
- ③ Assemble the ferrules (or sleeve) and nut into the die head.

### 2. OPERATION

- ① Turn on the power of the swaging unit.
- ② Set the pressure on the digital indicator (please refer to Pressure Setting table).
- ③ Insert the tube until it rests properly against the piston shoulder.
- ④ While holding the tubing end, press the start button of the swaging unit.
- ⑤ Beeping sound when the pre-swaging is completed.
- ⑥ Disassemble the nut and remove the pre-swaged tubing from the swaging unit.
- ⑦ Insert the pre-swaged tubing into the body of SUPERLOK Tube Fitting (or SUPERLOK DIN Tube Fitting) and tighten the nut until finger-tight.
- ⑧ Hold the fitting body stable and tighten the nut clockwise: one-second to three-fourth turn for SUPERLOK Tube Fitting (Double-ferrule type) and one-second turn for SUPERLOK DIN Tube Fitting (DIN2353 Bite-type)

## Ordering Information

### SWAGING UNIT

Example : **SMHS - AUE**  
1

#### 1. Type

- AMU = Automation Multi-head Hydraulic Swaging Unit     MU: Multi-head Hydraulic Swaging Unit     DH: Die Head

#### 2. Size of Die Head

##### 2-1 Fitting Type

- S = SUPERLOK Tube Fitting (Double Ferrule Compression type)  
 D = SUPERLOK DIN Tube Fitting (DIN 2353 Bite-type)

##### 2-3 Series

SUPERLOK Tube Fitting (Double Ferrule Compression type)	Tube O.D	Inch	Metric
	Designator	<b>(Blank)</b>	<b>M</b>

## Pressure Setting

### SUPERLOK Tube Fitting

Inch Size				
Die Head Part Number	316 Seamless Tubing & Wall Thickness			Set Pressure (bar)
	TUBE O.D (Inch)	Min. (Inch)	Max. (Inch)	
DH-S8	1/2	0.049	0.083	70
DH-S12	3/4	0.065	0.109	100
DH-S16	1	0.083	0.12	130
DH-S20	1-1/4	0.083	0.156	160
DH-S24	1-1/2	0.095	0.188	190
DH-S32	2	0.109	0.188	230

Metric Size				
Die Head Part Number	316 Seamless Tubing & Wall Thickness			Set Pressure (bar)
	TUBE O.D (mm)	Min. (mm)	Max. (mm)	
DH-S12M	12	1.2	2.0	80
DH-S16M	16	1.5	2.2	90
DH-S20M	20	1.8	2.8	100
DH-S22M	22	1.8	2.8	120
DH-S25M	25	2.2	3.0	130
DH-S28M	28	2.5	3.5	140
DH-S30M	30	2.5	3.5	150
DH-S32M	32	2.8	4.0	160
DH-S38M	38	3.0	4.5	190

### SUPERLOK DIN Tube Fitting (Bite-type)

Light (L) series				
Die Head Part Number	316 Seamless Tubing & Wall Thickness			Set Pressure (bar)
	TUBE O.D (mm)	Min. (mm)	Max. (mm)	
DH-D18L	18	1.5	2.0	90
DH-D22L	22	1.5	2.0	150
DH-D28L	28	1.5	2.0	130
DH-D35L	35	2.0	3.0	200
DH-D42L	42	2.0	3.0	230

Heavy (S) series				
Die Head Part Number	316 Seamless Tubing & Wall Thickness			Set Pressure (bar)
	TUBE O.D (mm)	Min. (mm)	Max. (mm)	
DH-D16S	16	1.5	3.0	100
DH-D20S	20	2.0	3.0	150
DH-D25S	25	2.5	3.0	130
DH-D30S	30	2.5	4.0	220
DH-D38S	38	3.0	4.0	230

### SWAGING UNIT – DIE HEAD

Example : **SMHS - DH - S 12 M**  
1    2-1    2-2    2-3

#### 2-2 Tube O.D

Fractional Tube	O.D (Inch)	1/2	3/4	1	1-1/4	1-1/2	2						
	Designator		<b>8</b>	<b>12</b>	<b>16</b>	<b>20</b>	<b>24</b>	<b>32</b>					
Metric Tube	O.D (Inch)	12	16	18	20	22	25	28	30	32	35	38	42
	Designator	<b>12</b>	<b>16</b>	<b>18</b>	<b>20</b>	<b>22</b>	<b>25</b>	<b>28</b>	<b>30</b>	<b>32</b>	<b>35</b>	<b>38</b>	<b>42</b>

SUPERLOK DIN Tube Fitting (DIN2353 Bite-type)	Series	Light	Heavy
	Designator		<b>L</b>

※ For special sizes and configurations, please consult BMT (SUPERLOK) sales representative.

# Tube Benders

## Features

- For bending soft copper, aluminum, brass, steel, stainless steel and other tubing.
- New design for accurate and tight bends up to 180° in stainless steel and other tough metals.
- Patented, quick action trigger release repositions two-stage handle midway through a bend when both handle begin to meet. This feature allows easy fabrication of optimized bends up to 180° with reduced effort, better control and no crossing of handles.
- Rollers in bending handle reduce friction and bending effort, eliminate scoring of tubing.
- Comfortable and durable ergonomically molded cushion grips.
- Vise lug for mounting in vise.
- Clamshell packaging available for 1/4" and 3/8" O.D models.



## Operating Procedures

1. Available the setting to adjust the pressure value according to the condition.
2. Activate the buzzer sound when complete to install in normal.
3. Assemble it to check the set pressure value by naked eye.
4. Available to use without electric power supply.

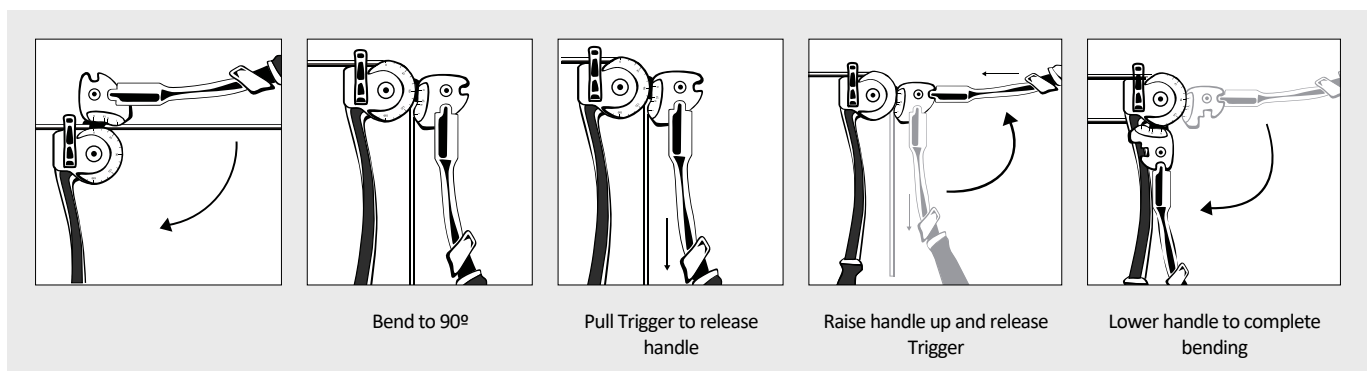

## Technical Data

Part No.	Tube OD	Raidius(to center of tube)	Weight (kg)
SDTB-4	1/4	9/16	0.54
SDTB-6	3/8	15/16	1.68
SDTB-8	1/2	1-1/2	3.45







# BMT Co., Ltd.

## | Head Quarter & 1st Factory

(50568) 경상남도 양산시 산막공단남11길 35 (북정동)

35, Sanmakgongdannam 11-gil, Yangsan-si, Gyeongsangnam-do, 50568, South Korea

TEL: +82 55 783 1000 FAX: +82 55 783 1111

E-mail: superlok@superlok.com

## | 2nd Factory

(50568) 경상남도 양산시 산막공단남8길 29 (호계동)

29, Sanmakgongdannam 8-gil, Yangsan-si, Gyeongsangnam-do, 50568, South Korea

## Fittings & Valves

### INDUSTRIAL

Instrumentation Tube Fittings

i-Fitting®

Ball/Plug Valves

Double Block & Bleed Valves

Manifold/Gauge Valves

Globe/Needle Valves

Cryogenic Valves

Check/Relief/Excess Flow Valves

High Pressure Valves

### ULTRA HIGH PURITY

Weld & Metal Face Seal Fittings

Bend Fittings

Diaphragm Valves

Bellows Valves

Check Valves

Clean Ball Valves

Regulators

## Electric & Energy

### PRODUCT & SOLUTION

Compact Switchboard

Motor Control Center (MCC)

Smart Distribution Board

Energy Management System (EMS)

### COMPONENTS (BMT PATENTED)

*MCBS* (Molded Case Busbar System)

*MCPD* (Molded Case Power Distributor)

*Smart-eye* (AC/DC Meter)