

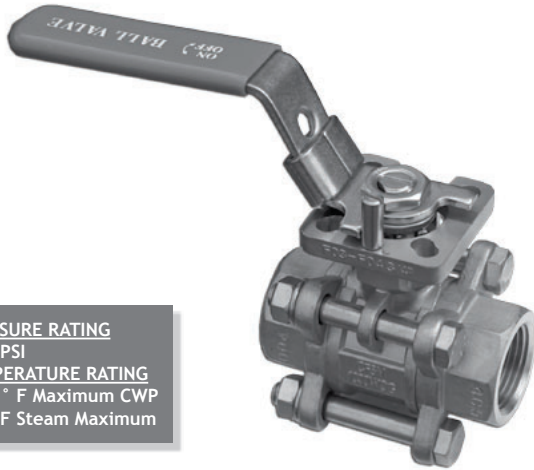

STAINLESS STEEL 3-PIECE BALL VALVE



PRESSURE RATING
1000PSI
TEMPERATURE RATING
+450° F Maximum CWP
366° F Steam Maximum

VALVE FEATURES

- Full port SS 3-piece valve
- 1/4" through 3"
- self-adjusting stem packing
- ideal for food and chemical applications
- swing-out 3-piece design for easy maintenance
- NPT, butt weld or socket weld
- ISO 5211 mounting pad for direct mount actuation

BILL OF MATERIALS

PART #	NAME	MATERIAL	QTY
1	END CAP	ASTM A351 CF8M	2
2	BODY SEAL	TFE	2
3	BALL	ASTM A351 CF8M	1
4	BODY	ASTM A351 CF8M	1
5	SEAT	RTFE	2
6	WASHER	304SS	4
7	NUT	304SS	1
8	STEM SEAL	TFE	1
9	O-RING	VITON®	1
10	STEM PACKING	TFE	1
11	BELLEVILLE WASHER	304SS	2
12	STEM NUT	304SS	1
13	STEM	316SS	1

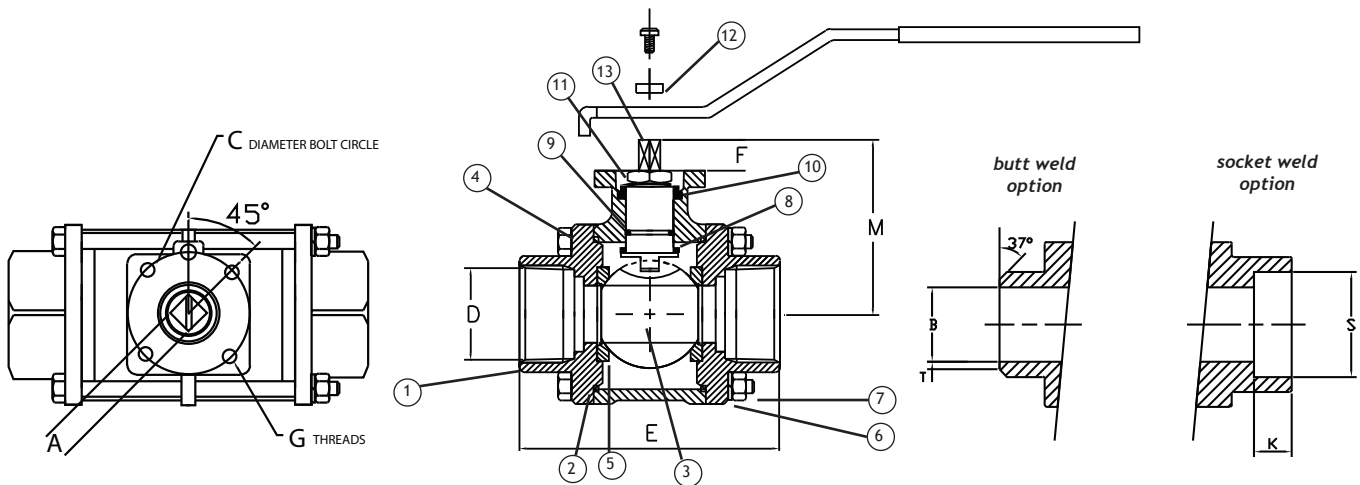

DIMENSIONAL DATA

SIZE	ISO 5211	A	B	C	D	E	F	G	K	M	S	T	CV	PSI	WEIGHT (LBS.)
1/4"	F03-04	0.354	0.45	1.42/1.65	0.45	2.36	0.354	0.22/0.28	0.40	1.93	0.86	0.04	6	1000	1.27
3/8"	F03-04	0.354	0.50	1.42/1.65	0.50	2.36	0.354	0.22/0.28	0.40	1.93	0.86	0.04	9	1000	1.27
1/2"	F03-04	0.354	0.59	1.42/1.65	0.59	2.95	0.354	0.22/0.28	0.50	1.93	0.86	0.04	21	1000	1.45
3/4"	F03-04	0.354	0.79	1.42/1.65	0.79	3.15	0.354	0.22/0.28	0.62	2.09	1.06	0.04	37	1000	1.75
1"	F04-05	0.433	0.98	1.65/1.97	0.98	3.45	0.551	0.28/0.35	0.69	2.60	1.33	0.06	58	1000	3.10
1-1/4"	F04-05	0.433	1.26	1.65/1.97	1.26	4.33	0.551	0.28/.035	0.75	2.83	1.67	0.06	93	1000	4.35
1-1/2"	F05-07	0.551	1.50	1.97/2.76	1.50	4.72	0.551	0.28/0.35	0.88	3.23	1.92	0.06	139	1000	6.65
2"	F05-07	0.551	1.97	1.97/2.76	1.97	5.51	0.551	0.28/0.35	0.88	3.63	2.41	0.09	232	1000	10.00
2-1/2"	F07-F10	0.669	2.50	2.76/4.02	2.50	6.54	0.790	0.28/0.35	0.88	4.41	2.91	0.10	371	800	21.30
3"	F07-10	0.669	3.14	2.76/4.02	3.14	7.40	0.790	0.35	1.00	4.81	3.54	0.10	557	800	30.00